

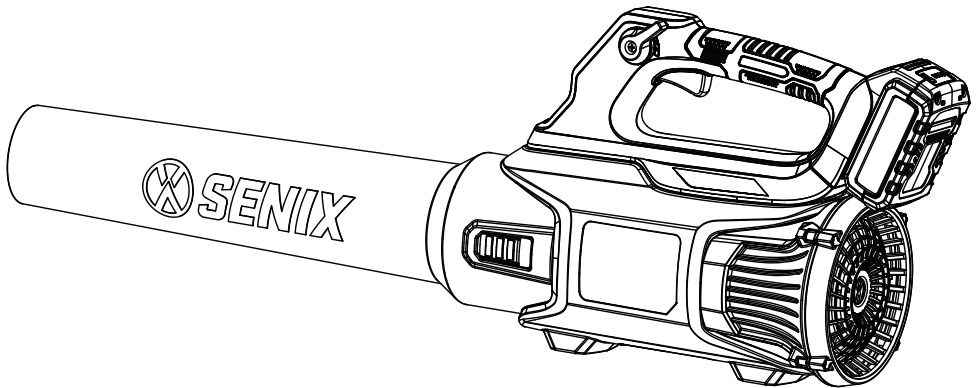

20V MAX LITHIUM ION AXIAL FAN BLOWER

Model: BLAX2-M
BLAX2-M-0



For customer service please find all information on www.senixtools.com
CAUTION: BEFORE USING THIS PRODUCT, READ THIS MANUAL AND
FOLLOW ALL ITS SAFETY RULES AND OPERATING INSTRUCTIONS.

ORIGINAL INSTRUCTIONS

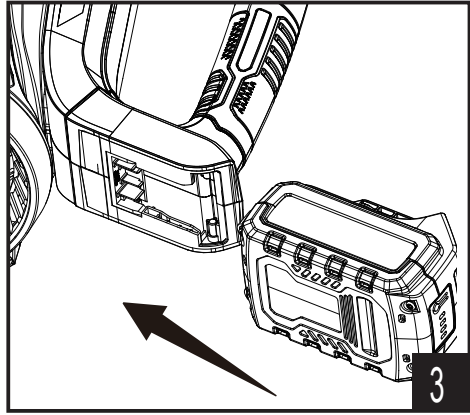
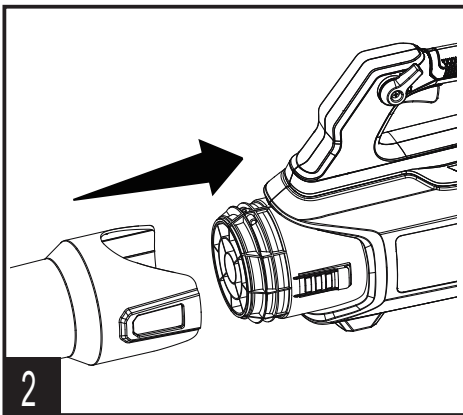
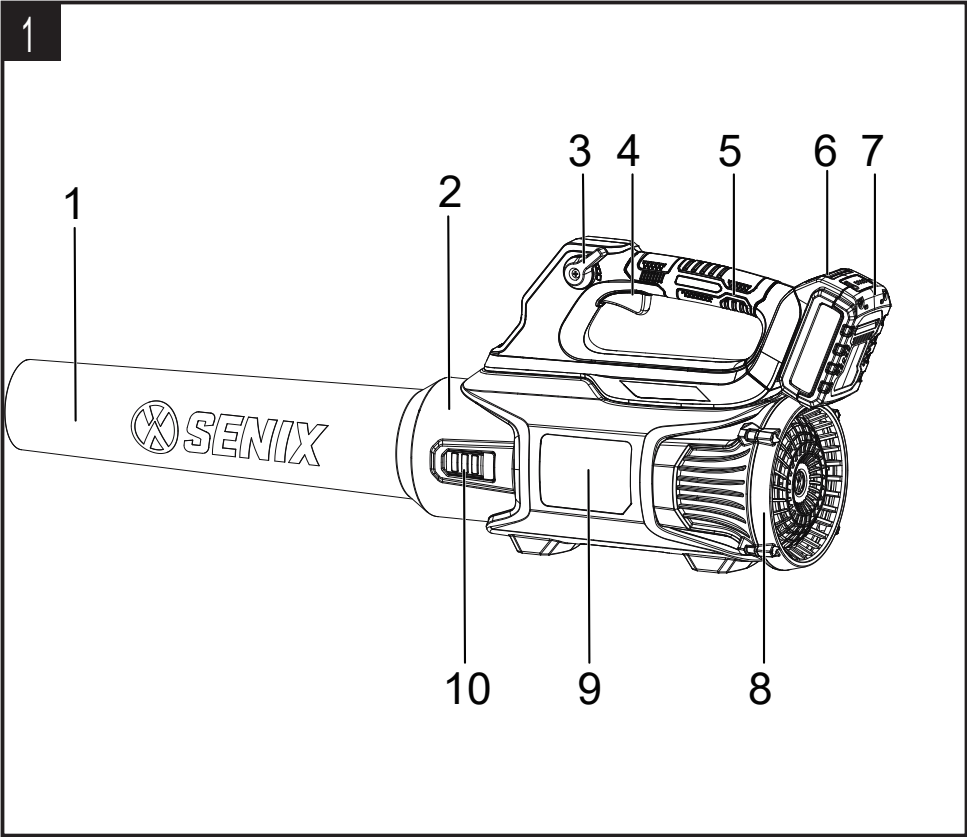

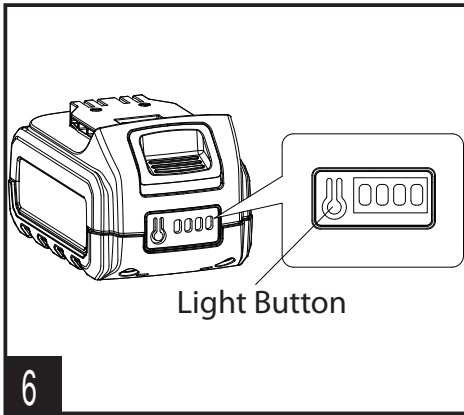
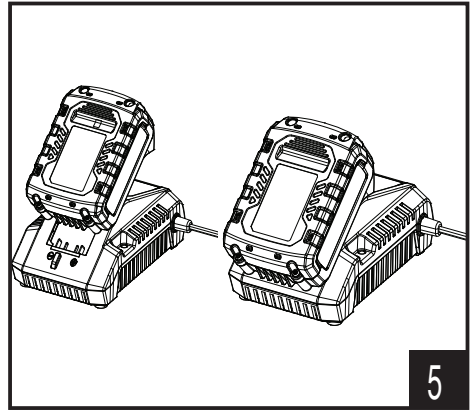
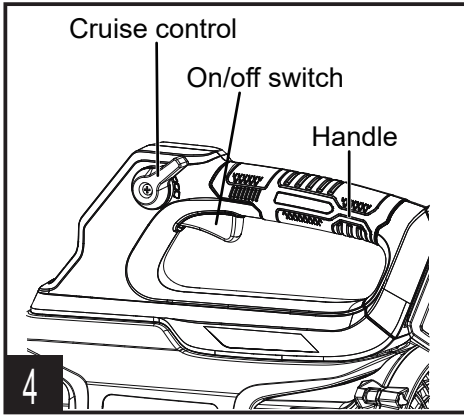

TABLE OF CONTENTS

SAFETY & INTERNATIONAL SYMBOLS	4
SAFETY INSTRUCTIONS.....	5
KNOW YOUR UNIT.....	15
SPECIFICATIONS*.....	15
ASSEMBLY.....	16
OPERATION.....	16
MAINTENANCE.....	18
TROUBLESHOOTING.....	19
RECYCLING AND DISPOSAL.....	19
PARTS.....	20
EC DECLARATION OF CONFORMITY.....	22

SAFETY & INTERNATIONAL SYMBOLS

Explanation of Safety & international symbols describes safety and international symbols and pictographs that may appear on this product. Read the operator's manual for complete safety, assembly, operating and maintenance and repair information.



Caution/ Warning.
WARNING-To reduce the risk of injury, user must read instruction manual.



Do not use in rain or wet conditions.



Wear eye protection



Risk of flying objects or debris.
Be aware of that there is a risk of flying objects and/or debris when using the machine.
Keep bystanders away.



Always wear ear protection.



Wear protective gloves.



Wear tight-fitted protective clothes.



Wear Sturdy, non-slip footwear.



Rotating blades. Keep hands and feet away from the openings, while the machine is running.



Guaranteed Sound power level 97 dB(A).



Use and store the battery within an temperature below 50°C.



Do not disassemble, crush, heat above 100°C ; Never expose the battery to microwaves or high pressures.



The product complies with the applicable European directives and an evaluation method of conformity for these directives was done.



WEEE symbol. Waste electrical products should not be disposed of with household waste. Please recycle where facilities exist. Check with your Local Authority or local store for recycling advice.



Crossed out dust bin. Batteries and battery packs should not be disposed of with household waste. Please recycle where facilities exist. Check with your Local Authority or local store for recycling advice.

SAFETY INSTRUCTIONS

GENERAL POWER TOOL SAFETY WARNINGS

WARNING!

Read all safety warnings and all instructions. Failure to follow the warnings and instructions may result in electric shock, fire and/or serious injury.

Save all warnings and instructions for future reference.

The term "power tool" in the warnings refers to your mains-operated (corded) power tool or battery-operated (cordless) power tool.

WORK AREA SAFETY

- a) Keep work area clean and well lit. Cluttered or dark areas invite accidents.
- b) Do not operate power tools in explosive atmospheres, such as in the presence of flammable liquids, gases or dust. Power tools create sparks which may ignite the dust or fumes.
- c) Keep children and bystanders away while operating a power tool. Distractions can cause you to lose control.

ELECTRICAL SAFETY

- a) Power tool plugs must match the

outlet. Never modify the plug in any way. Do not use any adapter plugs with earthed (grounded) power tools. Unmodified plugs and matching outlets will reduce risk of electric shock.

- b) Avoid body contact with earthed or grounded surfaces, such as pipes, radiators, ranges and refrigerators. There is an increased risk of electric shock if your body is earthed or grounded.
- c) Do not expose power tools to rain or wet conditions. Water entering a power tool will increase the risk of electric shock.
- d) Do not abuse the cord. Never use the cord for carrying, pulling or unplugging the power tool. Keep cord away from heat, oil, sharp edges or moving parts. Damaged or entangled cords increase the risk of electric shock. Not applicable for cordless power tools.
- e) When operating a power tool outdoors, use an extension cord suitable for outdoor use. Use of a cord suitable for outdoor use reduces the risk of electric shock. Not applicable for cordless power tools.

- f) If operating a power tool in a damp location is unavoidable, use a residual current device (RCD) protected supply. Use of an RCD reduces the risk of electric shock.
- d) Remove any adjusting key or wrench before turning the power tool on. A wrench or a key left attached to a rotating part of the power tool may result in personal injury.

PERSONAL SAFETY

- a) Stay alert, watch what you are doing and use common sense when operating a power tool. Do not use a power tool while you are tired or under the influence of drugs, alcohol or medication. A moment of inattention while operating power tools may result in serious personal injury.
- b) Use personal protective equipment. Always wear eye protection. Protective equipment such as dust mask, non-skid safety shoes, hard hat, or hearing protection used for appropriate conditions will reduce personal injuries.
- c) Prevent unintentional starting. Ensure the switch is in the off position before connecting to power source and/or battery pack, picking up or carrying the tool. Carrying power tools with your finger on the switch or energising power tools that have the switch on invites accidents.
- e) Do not overreach. Keep proper footing and balance at all times. This enables better control of the power tool in unexpected situations.
- f) Dress properly. Do not wear loose clothing or jewellery. Keep your hair, clothing and gloves away from moving parts. Loose clothes, jewellery or long hair can be caught in moving parts.
- g) If devices are provided for the connection of dust extraction and collection facilities, ensure these are connected and properly used. Use of dust collection can reduce dust-related hazards.

POWER TOOL USE AND CARE

- a) Do not force the power tool. Use the correct power tool for your application. The correct power tool will do the job better and safer at the rate for which it was designed.
- b) Do not use the power tool if the switch does not turn it on and

- off. Any power tool that cannot be controlled with the switch is dangerous and must be repaired.
- c) Disconnect the plug from the power source and/or the battery pack from the power tool before making any adjustments, changing accessories, or storing power tools. Such preventive safety measures reduce the risk of starting the power tool accidentally.
 - d) Store idle power tools out of the reach of children and do not allow persons unfamiliar with the power tool or these instructions to operate the power tool. Power tools are dangerous in the hands of untrained users.
 - e) Maintain power tools. Check for misalignment or binding of moving parts, breakage of parts and any other condition that may affect the power tool's operation. If damaged, have the power tool repaired before use. Many accidents are caused by poorly maintained power tools.
 - f) Keep cutting tools sharp and clean. Properly maintained cutting tools with sharp cutting edges are less likely to bind and are easier to control.
 - g) Use the power tool, accessories and tool bits etc. in accordance with these instructions, taking into account the working conditions and the work to be performed. Use of the power tool for operations different from those intended could result in a hazardous situation.

BATTERY TOOL USE AND CARE

- a) Recharge only with the charger specified by the manufacturer. A charger that is suitable for one type of battery pack may create a risk of fire when used with another battery pack.
- b) Use power tools only with specifically designated battery packs. Use of any other battery packs may create a risk of injury and fire.
- c) When battery pack is not in use, keep it away from other metal objects, like paper clips, coins, keys, nails, screws or other small metal objects, that can make a connection from one terminal to another. Shorting the battery terminals together may cause burns or a fire.
- d) Under abusive conditions, liquid may be ejected from the battery; avoid contact. If contact

accidentally occurs, flush with water. If liquid contacts eyes, additionally seek medical help. Liquid ejected from the battery may cause irritation or burns.

SERVICE

- a) Have your power tool serviced by a qualified repair person using only identical replacement parts. This will ensure that the safety of the power tool is maintained.
- b) Never service damaged battery packs. Service of battery packs should only be performed by the manufacturer or authorized service providers.

BLOWER SAFETY WARNINGS IMPORTANT READ CAREFULLY BEFORE USE KEEP FOR YOUR REFERENCE

1) Training

- a) Read the instructions carefully. Be familiar with the controls and the proper use of the product.
- b) Never allow children, persons with reduced physical, sensory or mental capabilities or lack of experience and knowledge or people unfamiliar with these instructions to use the machine. Local regulations may restrict

the age of the operator.

- c) Keep in mind, that the operator or user is responsible for accidents or hazards occurring to other people or their property.

2) Preparation

- a) Obtain ear protection and safety glasses. Wear them at all times while operating the machine.
- b) While operating the machine always wear substantial footwear and long trousers. Do not operate the machine when barefoot or wearing open sandals. Avoid wearing clothing that is loose fitting or that has hanging cords or ties.
- c) Do not wear loose clothing or jewellery that can be drawn into the air inlet. Keep long hair away from the air inlets.
- d) Operate the machine in a recommended position and only on a firm, level surface.
- e) Do not operate the machine on a paved or gravel surface where ejected material could cause injury.
- f) Before using, always visually inspect to see, that the shredding means, shredding means bolts and other fasteners are secure, the housing is

undamaged and that guards and screens are in place. Replace worn or damaged components in sets to preserve balance.

Replace damaged or unreadable labels.

- g) Before use, check the supply and extension cord for signs of damage or aging. If the cord becomes damaged during use, disconnect the cord from the supply immediately. **DO NOT TOUCH THE CORD BEFORE DISCONNECTING THE SUPPLY.** Do not use the machine if the cord is damaged or worn.
- h) Never operate the machine while people, especially children, or pets are nearby.

3) Operation

- a) Do not allow hands or any other part of the body or clothing near any moving parts.
- b) Keep proper balance and footing at all times. Do not overreach.
- c) Always stand clear of the working area when operating this product.
- d) If the cutting mechanism strikes any foreign objects or if the product should start making any unusual noise or vibration,

immediately shut off the power source and allow the product to stop. Disconnect the product from the supply and take the following steps before restarting and operating the product:

- inspect for damage;
- replace or repair any damaged parts;
- check for and tighten any loose parts.
- e) Never operate the product with defective guards or shields, or without safety devices.
- f) Keep the power source clean of debris and other accumulations to prevent damage to the power source or possible fire.
- g) Do not transport this product while the power source is running.
- h) Stop the product, shut off the power source and disconnect the product from the supply.
- i) Make sure that all moving parts have come to a complete stop:
 - whenever you leave the product,
 - before clearing blockages or unclogging chute,
 - before checking, cleaning or working on the product,
 - after striking a foreign object to inspect the machine for damage.

- if the machine starts to vibrate abnormally, for immediately check.
- j) Do not tilt the product while the power source is running.
- k) Walk, never run.
- l) Never operate the product near open windows, etc.
- m) Operate the product only in daylight or in good artificial light.
- n) Do not blow hard objects such as nails, bolts, or rocks.
- o) Apply extra care when cleaning debris from stairs or other tight areas.
- p) Follow below recommendations when using the product:
 - Use rakes and brooms to loosen debris before blowing.
 - Use the full blower nozzle extension

4) Maintenance and storage

- a) When the machine is stopped for servicing, inspection, or storage, or to change an accessory, shut off the power source, disconnect the machine from the supply and make sure that all moving parts are come to a complete stop. Allow the machine to cool before making any inspections, adjustments, etc. Maintain the machine with care and keep it clean.
- b) Store the machine in a dry place out of the reach of children.
- c) Always allow the machine to cool before storing.
- d) Replace worn or damaged parts for safety. Use only genuine replacement parts and accessories.
- e) Never attempt to override the interlocked feature of the guard.

VIBRATION AND NOISE REDUCTION

To reduce the impact of noise and vibration emission, limit the time of operation, use low-vibration and low-noise operating modes as well as wear personal protective equipment. Take the following points into account to minimise the vibration and noise exposure risks:

- Only use the product as intended by its design and these instructions.
- Ensure that the product is in good condition and well maintained.
- Use correct attachments for the product and ensure they are in good condition.
- Keep tight grip on the handle.
- Maintain this product in accordance with these instructions and keep it well lubricated (where

appropriate).

- Plan your work schedule to spread any high vibration tool use across a longer period of time.
- Prolonged use of the product exposes the user to vibrations that can cause a range of conditions collectively known as hand-arm vibration syndrome (HAVS) e. g. fingers going white; as well as specific afflictions such as carpal tunnel syndrome.
- To reduce this risk when using the product, always wear protective gloves and keep your hands warm.
- The symptoms of HAVS include any combination of the following: Tingling and numbness in the fingers; Not being able to feel things properly; loss of strength in the hands; fingers going white (blanching) and becoming red and painful on recovery (particularly in the cold and wet, and probably only in the tips at first). Seek medical advice immediately if such symptoms are experienced.

BATTERY PACK SAFETY WARNINGS

- Ensure the switch is in the off position before inserting battery pack. Inserting the battery pack into machines that have the switch

on can cause accidents.

- Use only original battery packs intended specifically for this machine. Use of any other battery packs may create a risk of injury and fire.
- Do not open the battery. Danger of short-circuiting.
- Protect the battery against heat (e. g., against continuous intense sunlight and fire) water and moisture. Danger of explosion.
- In case of damage and improper use of the battery, vapours may be emitted. Ventilate the area and seek medical help in case of complaints. The vapours can irritate the respiratory system.
- Use the battery pack only in product family. This measure alone protects the battery against dangerous overload.
- The battery can be damaged by pointed objects such as nails or screwdrivers or by force applied externally. An internal short circuit can occur and the battery can burn, smoke, explode or overheat.
- Do not short-circuit the battery. There is danger of explosion.
- Longest life and best performance can be obtained if the battery pack is charged when the air temperature is between 18°C

and 24°C. DO NOT charge the battery pack in an air temperature below 0°C, or above 50°C. This is important and will prevent serious damage to the battery pack. • Do not store the battery outside or in vehicles. Store the battery within an temperature between 0°C and 50°C.

- Occasionally clean the venting slots and contact pins of the battery pack using a soft, clean and dry brush.

BATTERY CHARGER SAFETY WARNINGS



Read all safety warnings and instructions before using the charger.



Only for indoor use!



Class II protection.

- This appliance is not intended for use by children and persons with physical, sensory or mental limitations or a lack of experience or knowledge. This appliance can be used by children aged from 8 years and above and persons with reduced physical, sensory or mental capabilities or lack of experience and knowledge if they have been given supervision or

instruction concerning use of the appliance in a safe way and understand the hazards involved. Children shall not play with the appliance. Cleaning and user maintenance shall not be made by children without supervision.

- Only charge the Lithium-Ion battery pack with a capacity of 2.5 Ah or 5 Ah as mentioned in this instruction manual. Do not charge nonrechargeable batteries.
- The battery and charger must be placed in a well ventilated area.
- Do not operate the battery charger on easily inflammable surfaces (e. g., paper, textiles, etc.) or surroundings. The heating of the battery charger during the charging process can pose a fire hazard.
- Do not cover the ventilation slots of the battery charger. Otherwise, the battery charger can overheat and no longer operate properly.
- The supply cord cannot be replaced. If the cord is damaged the appliance should be scrapped.
- If the supply cord is damaged, it must be replaced by the manufacturer, its service agent or similarly qualified persons in order to avoid a hazard.

EMERGENCY

Familiarize yourself with the use of this product by means of this instruction manual. Memorize the safety directions and follow them to the letter. This will help to prevent risks and hazards.

1. Always be alert when using this product, so that you can recognize and handle risks early. Fast intervention can prevent serious injury and damage to property.
2. Switch off the product and remove the battery pack if there are malfunctions. Have the product checked by a qualified professional and repaired, if necessary, before you operate it again.

INTENDED USE

This blower is only intended to be used for blowing leaves, garden waste such as grass, twigs and pine needles in domestic use. Do not use it for others purposes.

RESIDUAL RISKS

Even if you are operating this product in accordance with the provisions, residual risks will always still remain. The following dangers can arise in connection with the

structure and design of this product:

1. Health defects resulting from vibration emission if the product is being used over longer period of time or not adequately managed and properly maintained.
2. Injuries and damage to property to due to broken accessories or hidden objects that are suddenly dashed.
3. Injuries and damage to property to due to thrown and fallen objects.
4. Prolonged use of this product expose the operator to vibrations and may produce 'whitefinger' disease. In order to reduce the risk, please wear gloves and keep your hands warm. If any of the 'whitefinger' symptoms appear, seek medical advice immediately. 'Whitefinger' symptoms include: numbness, loss of feeling, tingling, pricking, pain, loss of strength, changes in skin colour or condition. These symptoms normally appear in the fingers, hands or wrists. The risk increases at low temperatures.



This product produces an

electromagnetic field during operation! This field may under some circumstances interfere with active or passive medical implants! To reduce the risk of serious or fatal injury, we recommend persons with medical implants to consult their physician and the medical implant manufacturer before operating this product!

KNOW YOUR UNIT

APPLICATIONS

Model: BLAX2-M

BLAX2-M-0

As a blower:

•Blowing leaves, garden waste such as grass, twigs and pine needles in domestic use.

1	Blower tube
2	Tube housing
3	Cruise control
4	On/Off switch
5	Handle
6	Unlock button for battery pack
7	Battery
8	Air inlet cover
9	Cover
10	Blower tube release button

SPECIFICATIONS*



NOTE:

BLAX2-M does not include the charger and battery pack.

Model	BLAX2-M
Input voltage	18V d.c.
No-load speed	0-16800min ⁻¹ ±10%
Max. air speed	35m/s
Max. air volume	570m ³ /h
Sound pressure level	78.5dB(A),K= 3dB(A)
Measured sound power level	93.3dB(A),K=1.92dB(A)
Guarantee sound power level	97dB(A)
Vibration level(K=1.5 m/s ²)	0.689m/s ²
Weight without battery pack	2.15kg

Battery pack model for option	B20X2
Rated voltage	20V
Rated capacity	2.0Ah
Weight	Approx.0.335kg
Battery pack model for option	B40X2

Rated voltage	20V
Rated capacity	4.0Ah
Weight	Approx.0.65kg

Charger model for option	CHX2
Rated input	100-240V ~ 50/60Hz
Rated output	22.5±0.5V, 2±0.2A
Charging time (with 2.0 Ah battery)	75mins
Charging time (with 4.0 Ah battery)	140mins
Protection class	□ / II
Weight	Approx. 0.34kg
Charger model for option	CHQX2
Rated input	100-240V ~ 50/60Hz
Rated output	22±1V, 4±0.3A
Charging time (with 2.0 Ah battery)	35mins
Charging time (with 4.0 Ah battery)	70mins
Protection class	□ / II
Weight	Approx. 0.482kg

NOISE/VIBRATION INFORMATION

The declared vibration total value(s) and the declared noise emission value(s) have been measured in accordance with a standard test method and may be used for comparing one tool with another. They may also be used in a preliminary assessment of exposure.



WARNING!



The vibration and noise emissions during actual use of the power tool can differ from the declared values depending on the ways in which the tool is used especially what kind of workpiece is processed.

It is necessary to identify safety measures to protect the operator that are based on an estimation of exposure in the actual conditions of use (taking account of all parts of the operating cycle such as the times when the tool is switched off and when it is running idle in addition to the trigger time).

Please try to minimize the exposure of vibration and noise. Typical measure for reducing exposure will be wearing of hand gloves and

hearing protection during operation, limiting working time and applying accessories in good condition.

ASSEMBLY

1. Unpack all parts and lay them on a flat, stable surface:
2. Remove all packing materials and shipping devices, if applicable.
3. The scope of delivery varies depending on the country and purchased variant:
Model of BLAX2-M-EU
 - Blower x1
 - Blower tube x1
 - Instruction manual x1
 - Battery pack x1
 - Charger x1
4. If you find that parts are missing or show damage do not use the product but contact your dealer. Using an incomplete or damaged product represents a hazard to people and property.
5. Ensure that you have all the accessories and tools needed for assembly and operation. This also includes suitable personal protective equipment.



NOTE:

BLAX2-M does not include the charger and the battery pack.



WARNING!



Wear protective gloves for this assembly work and always lay the product on a flat and stable surface while assembling.



Follow the assembly instructions step-by-step and use the pictures provided as a visual guide to easily assemble the product!

Do not insert the battery pack before the power tool is completely assembled or adjusted!

INSTALLING THE BLOWER TUBE



WARNING!

To avoid serious personal injury and damage to the unit, shut the unit off before removing or installing an attachment.

Align the blower tube to the tube housing assembly. First insert the blower tube to the tube housing by assembling the blower tube release button to the slot of the tube housing (Fig. 2).



NOTE:

Take care of small parts that are removed during assembly or when making adjustments. Keep them secure to avoid loss.

INSTALLING/REMOVING THE BATTERY PACK

To install: Align the battery pack to the bottom of the handle and slide the battery pack into the power tool until it is locked in position (Fig. 3).

To remove: To release, press the release button for battery pack of the product and remove the battery pack from the product .

OPERATION



WARNING!

In some countries regulations define at what time of the day and on what special days products are allowed to be used and what restrictions apply!

Ask your community for detailed information and observe the regulations in order to preserve a peaceful neighborhood and avoid committing administrative offences.

The cover of the battery pack is broken, or the battery pack may discharge continuously for too long, and the temperature of the battery pack is too high, which will lead to leakage of the battery pack. Once the leakage occurs, shut down the unit, take out the battery pack and recycle it to the manufacturer.

SWITCHING ON/OFF

Hold the product as in working condition.

To start the product, press the on/off switch to turn the product on, dial the cruise control counterclockwise to lock the on/off switch to keep the on position.

To switch the product off, dial the cruise control clockwise, and the on/off switch can be released automatically, or release the on/off switch without setting the cruise control (Fig. 4).



WARNING!

The product will continue to work for some time even after the motor has been switched off! Wait until it comes to a complete stop before putting the product down!

ADJUSTING THE BLOWING SPEED

The blowing speed can be changed either hold the on/off switch towards to the handle or dial the cruise control counterclockwise.

OPERATING HOURS

Only operate the product at reasonable hours - not early in the morning, late at night or on weekends/ public holidays when people might be disturbed. Inform yourself about local restrictions.

GENERAL

1. Double check that accessories or application tools are properly fixed.
2. Always hold the product on its handle(s)/gripping surface(s). Keep the handle(s)/gripping surface(s) dry and clean to ensure safe support.
3. Ensure that the air vents are always unobstructed and clear. Clean them if necessary with a soft brush. Blocked air vents may lead to overheating and damage the product.
4. Switch the product off immediately if you are disturbed while working by other people entering the working area. Always let the product come to complete stop before putting it down.
5. Do not overwork yourself. Take regular breaks to ensure you can concentrate on the work and have full control over the product.
6. Before switching the product on, check whether it has been assembled correctly and all the moving parts are running smoothly!
7. While working, ensure that the product does not strike hard objects, as this can cause damage.
8. Do not blow any solid bodies such as stones, branches or pieces of branch, fir cones or similar.
9. We recommend slightly dampening surfaces in dusty conditions or using a mister attachment.

BLOWING

1. Before blowing, loosen leaves that are stuck to the ground using a broom or rake.
2. Hold the tube approximately 10 cm above the ground and walk slowly forward using a sweeping motion from side to side.
3. Direct the air stream away from yourself.
4. Ensure that you do not stir up any heavy objects and hurt somebody or damage something.

The risk of the operation may occurs, such as the sharp tree branches may cut the user's skin, the blade of the unit

may hurt the user's body. Always wear eye, hearing, hand, foot and body protection to reduce the risk of injury when operating this unit.

CHARGING THE BATTERY PACK



WARNING!

This Lithium-Ion battery pack is shipped partially charged. Fully charge the battery pack before using it for the first time.

1. Charge the Lithium-Ion battery pack only with the correct charger.
2. Connect the charger to a power supply, the light indicator of the charger turns red.
3. Align the raised ribs of the battery pack with the slot in the charger.
4. Insert the battery pack into the charger, the light indicator of the charger turns green and it flashes (Fig. 5).
5. The charger will communicate with the battery pack to evaluate the condition of the battery pack.
6. It is fully charged that the four lights of the battery turn on. Disconnect the power supply from the charger. Remove battery pack from the charger.

CHARGING INDICATOR

Press the light button on the battery pack to check whether it needs to charge (Fig. 6) .

Lights			Status
Lighted	Off	Blinking	
			The battery is at full capacity.
			The battery is at 75% capacity.
			The battery is at 50% capacity and requires charging.
			The battery is at 25% capacity and requires charging soon.
			The battery is less than 5% capacity and requires charging immediately.



WARNING!

Malfunctions may occur when the four lights blink in turns.

OVERHEAT PROTECTION

When the tool/battery is overheated, the tool stops automatically. In this situation, let the power tool/battery cool before turning the tool on again.

OVERDISCHARGE PROTECTION

When the battery capacity is not enough, the tool stops automatically. In this case, remove the battery from the tool and charge the battery.

MAINTENANCE

GENERAL RECOMMENDATIONS

The warranty on this unit does not cover items that have been subjected to operator abuse or negligence. To receive full value from the warranty, the operator must maintain unit as instructed in this manual. Various adjustments will need to be made periodically to properly maintain your unit.



NOTE:

Use only original equipment manufacturer replacement parts and accessories for this unit. These are available from an authorized service dealer. The use of any unauthorized parts or accessories could lead to serious injury to the user, or damage to the unit, and void the warranty. Press the unlock button for battery pack of the product and remove the battery pack from the product before cleaning and maintenance of the equipment.

CLEANING

Use a small brush to clean the outside of the unit. Do not use strong detergents. Household cleaners that contain aromatic oils such as pine and lemon, and solvents such as kerosene, can damage plastic. Wipe off any moisture with a soft cloth.

Correct and regular cleaning is not only important for the safe use of this product, but also extends its life span.

MAINTENANCE

Don't use detergent to clean the plastic parts of the device. A mild detergent on a damp cloth is recommended. The tool should never come in contact with water.

When the blower vibrates abnormally, immediately shut off the unit. Abnormal vibration often shows a mechanical problem and continues use could result in injury or property damage. Do not attempt to repair the unit yourself. There are no serviceable parts inside. Lubrication is not necessary since the motor is equipped with sufficient grease for the lifetime of the device.

When the blower is not working, shut the unit off, and press the unlock button for battery pack of the product and remove the battery pack from the product.



WARNING!

Installation, operation, or maintenance of the supported product should be carried out only by skilled persons.

During the maintenance, users should take care of their safety. Always wear eye, hearing, hand, foot and body protection to reduce the risk of injury when operating this unit. And check the unit that it can work normally after the maintenance. If any deterioration occurs, follow the maintenance according to this instruction!

STORAGE

1. Clean the product as described above.
2. Store the product and its accessories in a dark, dry, frost-free, well-ventilated place.
3. Always store the product in a place that is inaccessible to children. The ideal storage temperature is between 10 °C and 30 °C.
4. We recommend using the original package for storage or covering the product with a suitable cloth or enclosure to protect it against dust.

TRANSPORT

1. Clean the product as described above.
2. Always carry the product by its handle.
3. Protect the product from any heavy impact or strong vibrations which may occur during transportation in vehicles.
4. Secure the product to prevent it from slipping or falling over, damage or injury.

TROUBLESHOOTING

Suspected malfunctions are often due to causes that the users can fix themselves. Therefore, check the product using this section. In most cases the problem can be solved quickly.

PROBLEM	POSSIBLE CAUSE	SOLUTION
Product does not reach full power	Battery pack capacity too low	Charge battery pack
	Air vents are blocked	Clean the air vents
Product does not start	Battery pack not properly attached	Attach properly
	Battery pack capacity too low	Remove and charge battery pack
	Battery pack damaged	Check by a specialist electrician
	On/off switch not set on ON position	Refer to chapter "SWITCHING ON AND OFF"
Result is unsatisfactory	Cutting attachment is worn	Replace with a new one
Vibration or noise is excessive	Bolts/nuts are loose	Tighten bolts/nuts
Product suddenly stops	Battery pack capacity too low	Remove and charge battery pack
	Battery too hot	Remove battery pack and let it cool down

RECYCLING AND DISPOSAL



Disposal of waste electric and electronic equipment (WEEE)

Waste electric and electronic equipment shall not be disposed of with household waste. Please recycle where facilities exist. Check with your local authority for recycling advice.



Disposal of defective or used battery pack
Discharge your battery pack by operating your tool, then remove the battery pack from the tool. Cover the battery pack connections with heavy duty adhesive tape to prevent short circuit and energy discharge.

Do not attempt to open or remove any of the components.

Batteries and battery packs shall not be disposed of with household waste. Consult your local waste authority for information regarding available recycling and/or disposal options.

PARTS

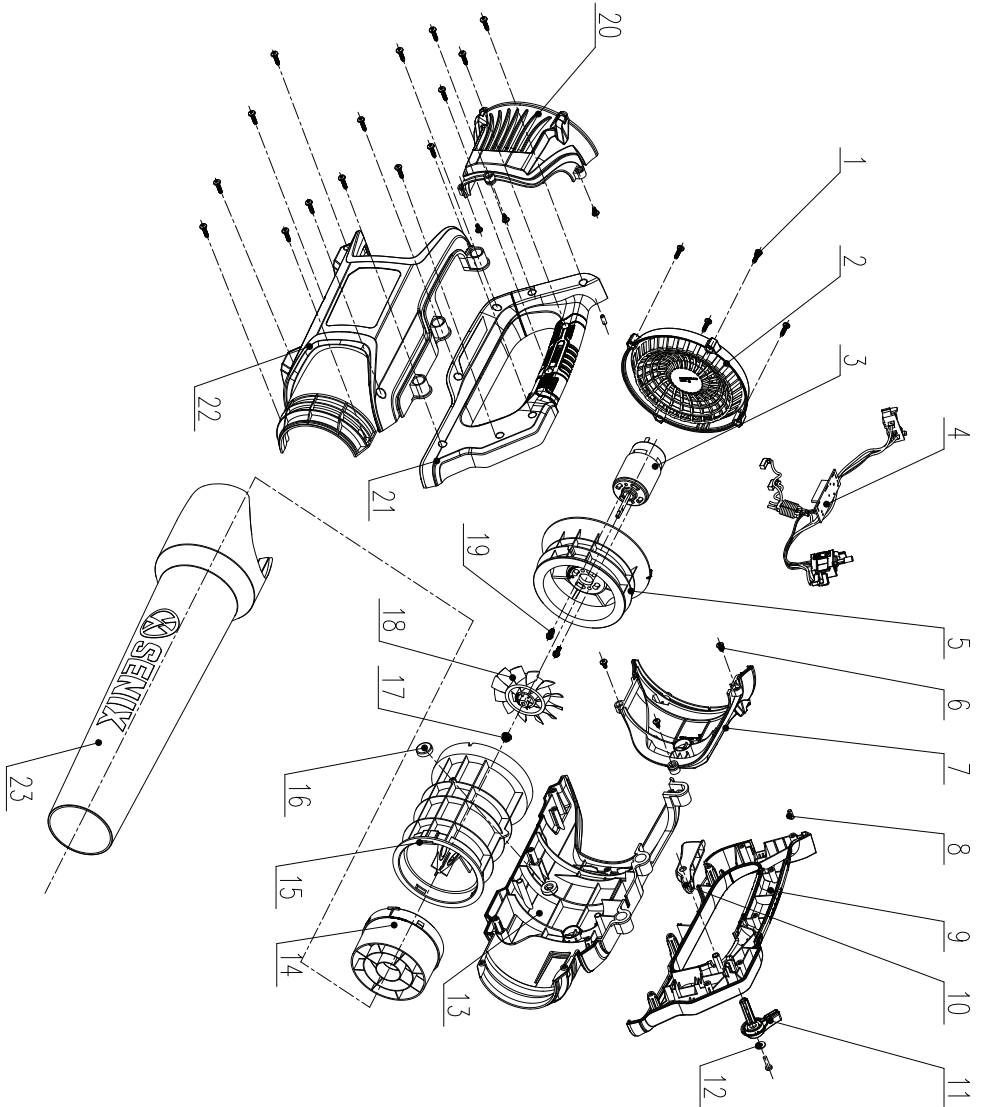

No.	Part #	Description	Qty.
1	8SJAB40-16	Self tapping screw	20
2	A075017-029-00	Air inlet	1
3	A075012-011-00	Motor assembly	1
4	A075016-010-00	Motor assembly	1
5	A075016-002-00	Current collector	1
6	8SJAB40-08	Self tapping screw	6
7	A075016-007-00	Left decorative cover	1
8	B048019-034-00	Rubber pin	2
9	A075016-005-00	Left handle cover	1
10	A075010-006-00	Trigger	1
11	A075010-007-00	Button	1
12	8WF-05B	Plain washer	1
13	A075017-002-00	Left housing	1
14	A075016-011-00	Guard board	1
15	A075016-003-00	Rectifier	1
16	A075010-016-00	Vibration reduction sleeve	2
17	8NA-05DL	Prevailing torque type hexagon nuts with flange(with non-metallic insert)	1
18	A075016-004-00	Fan blade	1
19	8SJGN04-14	Composite groove pan head three combination drop resistant screw	2
20	A075016-008-00	Right decorative cover	1
21	A075016-006-00	Right handle cover	1
22	A075017-003-00	Right housing	1
23	A075017-029-00	Blower tube	1

