

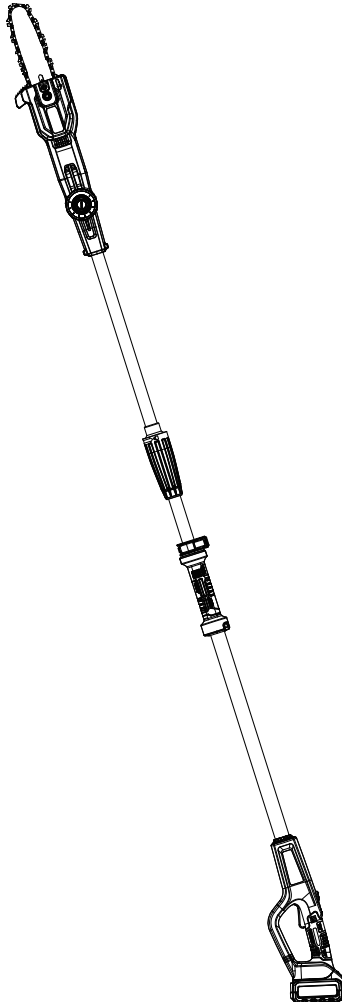

20V MAX LITHIUM ION CORDLESS POLE SAW

Model: CSPX2-M
CSPX2-M-0



For customer service please find all information on www.senixtools.com
CAUTION: BEFORE USING THIS PRODUCT, READ THIS MANUAL AND
FOLLOW ALL ITS SAFETY RULES AND OPERATING INSTRUCTIONS.

ORIGINAL INSTRUCTIONS

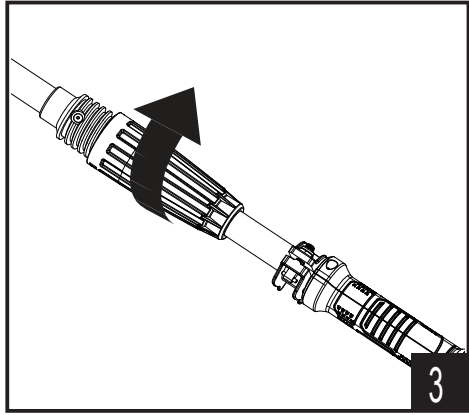
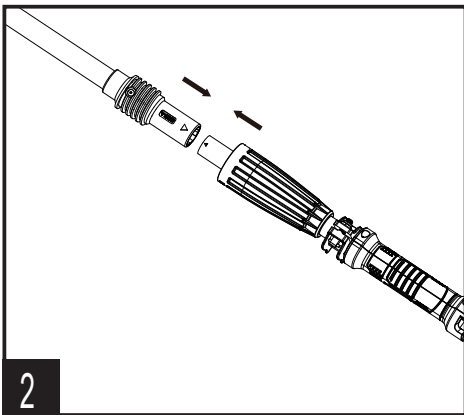
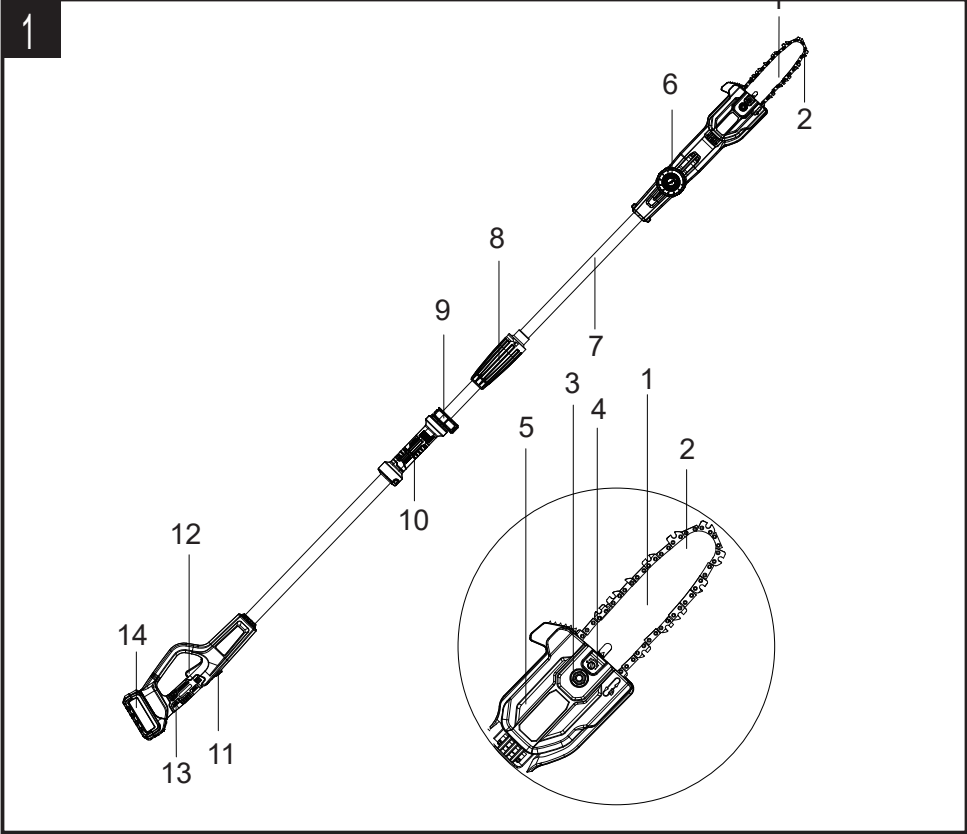

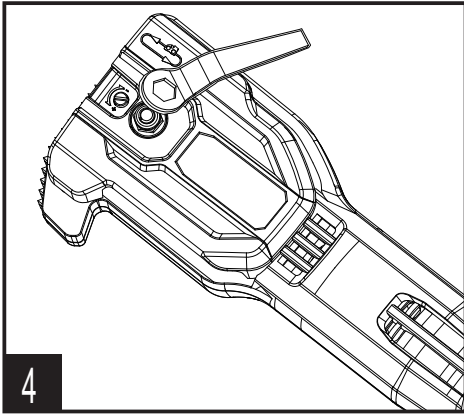

4

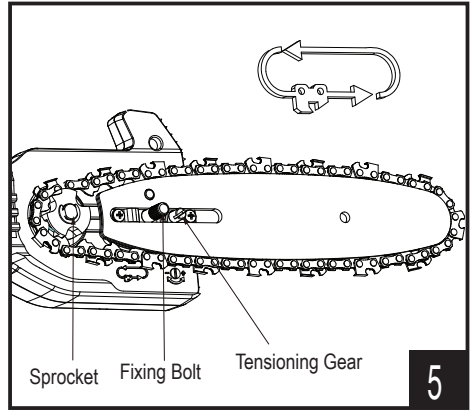

Sprocket Fixing Bolt Tensioning Gear

5

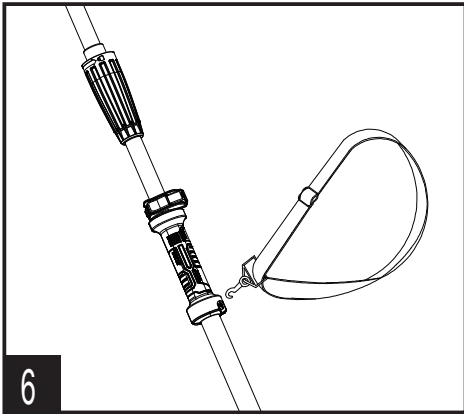

6

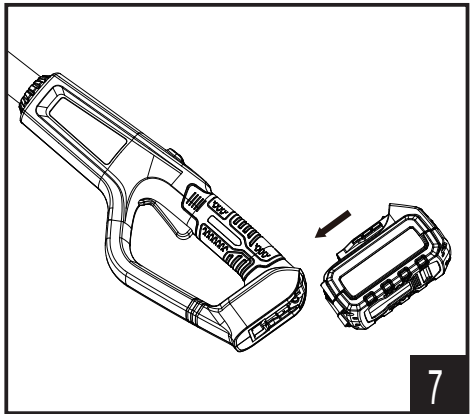

7

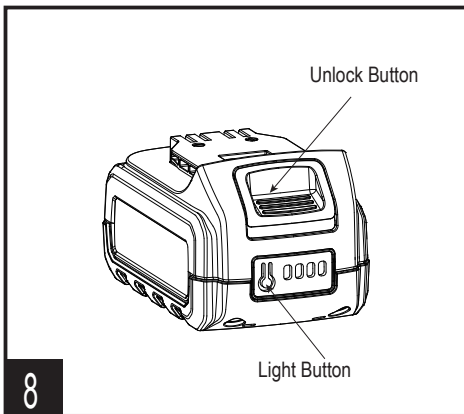

Unlock Button

Light Button

8

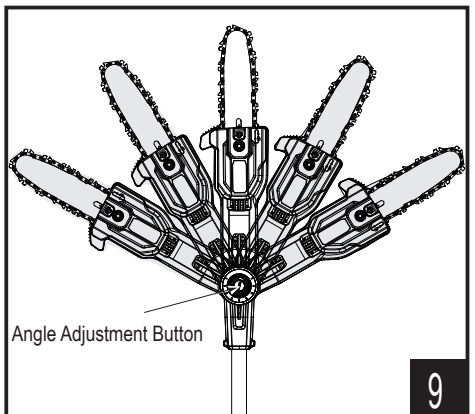

Angle Adjustment Button

9

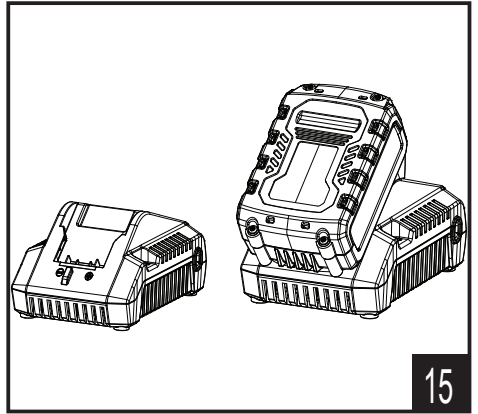
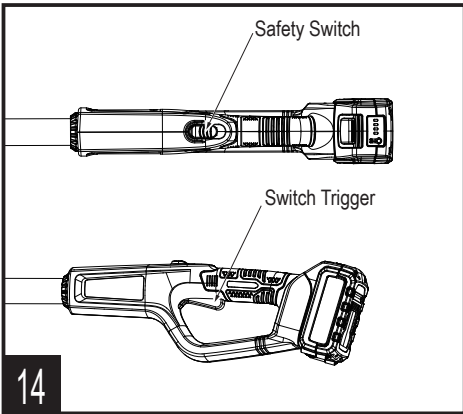
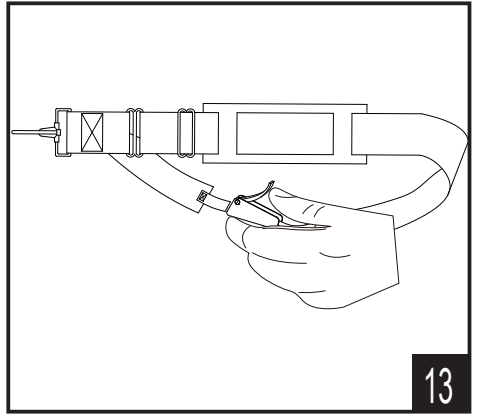
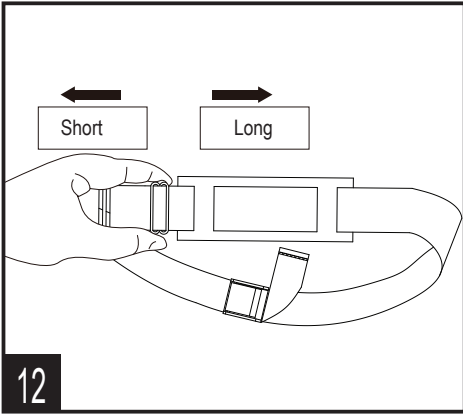
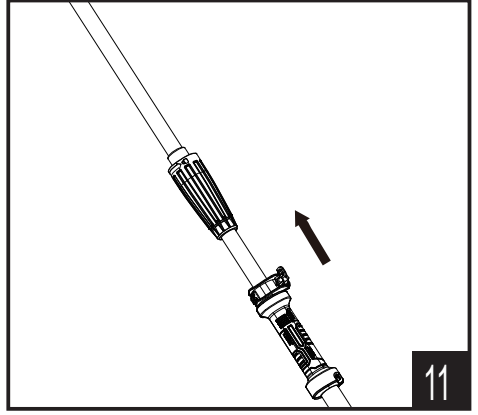
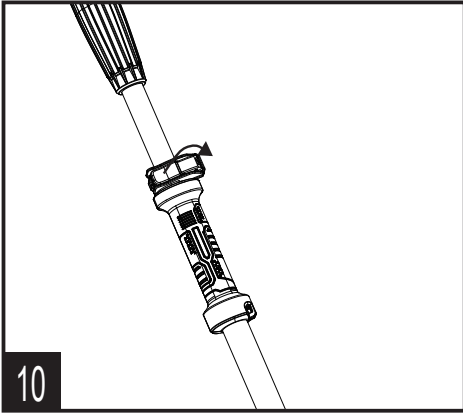

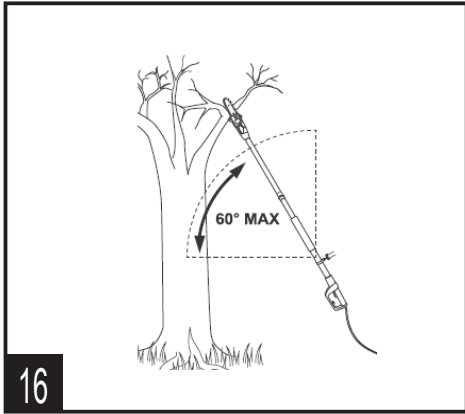

16

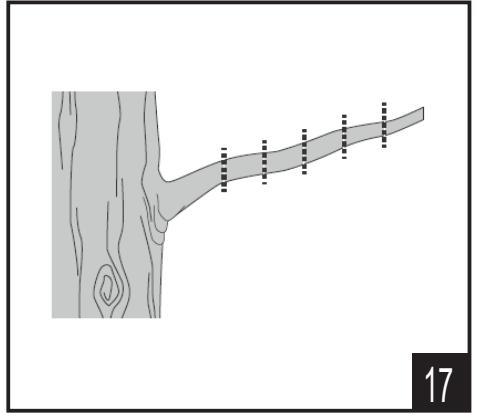

17

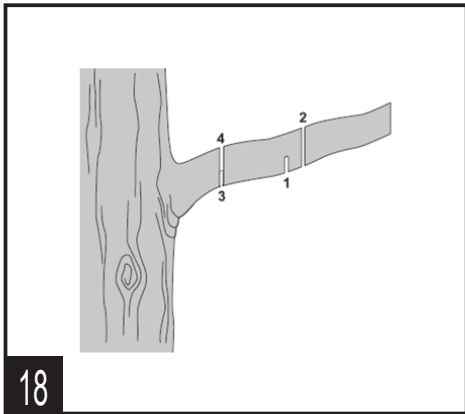

18

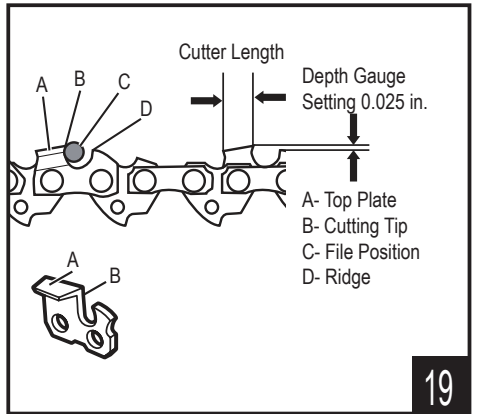

19

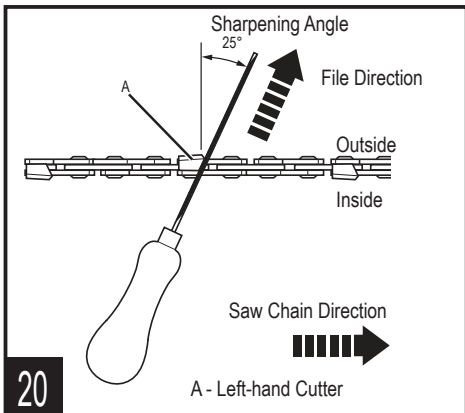

20

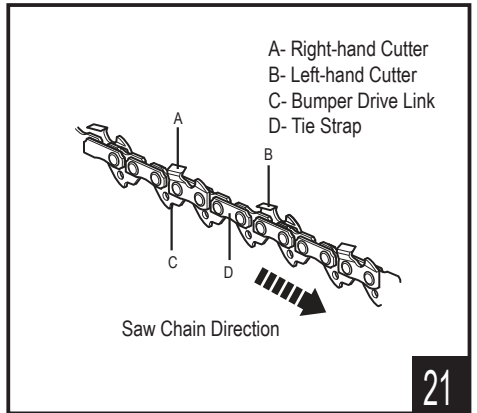

21

TABLE OF CONTENTS

SAFETY & INTERNATIONAL SYMBOLS	6
SAFETY INSTRUCTIONS.....	7
KNOW YOUR UNIT.....	17
SPECIFICATIONS*.....	17
ASSEMBLY.....	18
OPERATION.....	19
MAINTENANCE.....	22
TROUBLESHOOTING.....	24
RECYCLING AND DISPOSAL.....	24
PARTS.....	25

SAFETY & INTERNATIONAL SYMBOLS

Explanation of Safety & international symbols describes safety and international symbols and pictographs that may appear on this product. Read the operator's manual for complete safety, assembly, operating and maintenance and repair information.



Caution / Warning.



To reduce the risk of injury, user must read instruction manual.



Always wear ear protection.



Wear protective gloves.



Always wear eye protection.



Wear a dust mask.



Wear Sturdy, non-slip footwear.



Wear tight-fitting protective clothes.



Maintain a minimum clearance of 10 m from current-carrying lines. Life-threatening danger from electric shock.



Switch the product off and remove the battery pack to disconnect from the power supply before assembly, cleaning, adjustments, maintenance, storage and transportation.

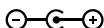

Polarity symbol of charger jack output +/-



Do not dispose of battery packs in rivers or immerse in water.



Do not dispose of battery packs in fire. They will explode and cause injury.



Use and store the battery within an temperature below 50°C.



Do not disassemble, crush, heat above 100°C ; Never expose the battery to microwaves or high pressures.



This charger is of protection class II. That means it is equipped with enhanced or double insulation.



The product complies with the applicable European directives and an evaluation method of conformity for these directives was done.



WEEE symbol. Waste electrical products should not be disposed of with household waste. Please recycle where facilities exist. Check with your Local Authority or local store for recycling advice.



Crossed out dust bin. Batteries and battery packs should not be disposed of with household waste. Please recycle where facilities exist. Check with your Local Authority or local store for recycling advice.



Guaranteed sound power level value in 95 dB(A)

SAFETY INSTRUCTIONS

GENERAL POWER TOOL SAFETY WARNINGS

WARNING!

Read all safety warnings, instructions, illustrations and specifications, provided with this power tool. Failure to follow all instructions listed below may result in electric shock, fire and/or serious injury.

Save all warnings and instructions for future reference.

The term "power tool" in the warnings refers to your mains-operated (corded) power tool or battery-operated (cordless) power tool.

1) Work Area Safety

- a) Keep work area clean and well lit. Cluttered or dark areas invite accidents.
- b) Do not operate power tools in explosive atmospheres, such as in the presence of flammable liquids, gases or dust. Power tools create sparks which may ignite the dust or fumes.
- c) Keep children and bystanders away while operating a power tool. Distractions can cause you to lose control.

2) Electrical Safety

- a) Power tool plugs must match the outlet. Never modify the plug in any way. Do not use any adapter plugs with earthed (grounded) power tools. Unmodified plugs and matching outlets will reduce risk of electric shock.
- b) Avoid body contact with earthed or grounded surfaces, such as pipes, radiators, ranges and refrigerators. There is an increased risk of electric shock if your body is earthed or grounded.
- c) Do not expose power tools to rain or wet conditions. Water entering a power tool will increase the risk of electric shock.
- d) Do not abuse the cord. Never use the cord for carrying, pulling or unplugging the power tool. Keep cord away from heat, oil, sharp edges or moving parts. Damaged or entangled cords increase the risk of electric shock.
- e) When operating a power tool outdoors, use an extension cord suitable for outdoor use. Use of a cord suitable for outdoor use reduces the risk of electric shock.

- f) If operating a power tool in a damp location is unavoidable, use a residual current device (RCD) protected supply. Use of an RCD reduces the risk of electric shock.
- d) Remove any adjusting key or wrench before turning the power tool on. A wrench or a key left attached to a rotating part of the power tool may result in personal injury.

3) Personal Safety

- a) Stay alert, watch what you are doing and use common sense when operating a power tool. Do not use a power tool while you are tired or under the influence of drugs, alcohol or medication. A moment of inattention while operating power tools may result in serious personal injury.
- b) Use personal protective equipment. Always wear eye protection. Protective equipment such as a dust mask, non-skid safety shoes, hard hat or hearing protection used for appropriate conditions will reduce personal injuries.
- c) Prevent unintentional starting. Ensure the switch is in the off-position before connecting to power source and/or battery pack, picking up or carrying the tool. Carrying power tools with your finger on the switch or energising power tools that have the switch on invites accidents.
- e) Do not overreach. Keep proper footing and balance at all times. This enables better control of the power tool in unexpected situations.
- f) Dress properly. Do not wear loose clothing or jewellery. Keep your hair and clothing away from moving parts. Loose clothes, jewellery or long hair can be caught in moving parts.
- g) If devices are provided for the connection of dust extraction and collection facilities, ensure these are connected and properly used. Use of dust collection can reduce dust-related hazards.
- h) Do not let familiarity gained from frequent use of tools allow you to become complacent and ignore tool safety principles. A careless action can cause severe injury within a fraction of a second.

4) Power Tool Use And Care

- a) Do not force the power tool. Use

the correct power tool for your application. The correct power tool will do the job better and safer at the rate for which it was designed.

- b) Do not use the power tool if the switch does not turn it on and off. Any power tool that cannot be controlled with the switch is dangerous and must be repaired.
- c) Disconnect the plug from the power source and/or remove the battery pack, if detachable, from the power tool before making any adjustments, changing accessories, or storing power tools. Such preventive safety measures reduce the risk of starting the power tool accidentally.
- d) Store idle power tools out of the reach of children and do not allow persons unfamiliar with the power tool or these instructions to operate the power tool. Power tools are dangerous in the hands of untrained users.
- e) Maintain power tools and accessories. Check for misalignment or binding of moving parts, breakage of parts and any other condition that may affect the power tool's operation.

If damaged, have the power tool repaired before use. Many accidents are caused by poorly maintained power tools.

- f) Keep cutting tools sharp and clean. Properly maintained cutting tools with sharp cutting edges are less likely to bind and are easier to control.
- g) Use the power tool, accessories and tool bits etc. in accordance with these instructions, taking into account the working conditions and the work to be performed. Use of the power tool for operations different from those intended could result in a hazardous situation.
- h) Keep handles and grasping surfaces dry, clean and free from oil and grease. Slippery handles and grasping surfaces do not allow for safe handling and control of the tool in unexpected situations.

5) Battery Tool Use And Care

- a) Recharge only with the charger specified by the manufacturer. A charger that is suitable for one type of battery pack may create a risk of fire when used with another battery pack.
- b) Use power tools only with

specifically designated battery packs. Use of any other battery packs may create a risk of injury and fire.

- c) When battery pack is not in use, keep it away from other metal objects, like paper clips, coins, keys, nails, screws or other small metal objects, that can make a connection from one terminal to another. Shorting the battery terminals together may cause burns or a fire.
- d) Under abusive conditions, liquid may be ejected from the battery; avoid contact. If contact accidentally occurs, flush with water. If liquid contacts eyes, additionally seek medical help. Liquid ejected from the battery may cause irritation or burns.
- e) Do not use a battery pack or tool that is damaged or modified. Damaged or modified batteries may exhibit unpredictable behaviour resulting in fire, explosion or risk of injury.
- f) Do not expose a battery pack or tool to fire or excessive temperature. Exposure to fire or temperature above 130 °C may cause explosion.
- g) Follow all charging instructions and do not charge the battery

pack or tool outside the temperature range specified in the instructions. Charging improperly or at temperatures outside the specified range may damage the battery and increase the risk of fire.

6) Service

- a) Have your power tool serviced by a qualified repair person using only identical replacement parts. This will ensure that the safety of the power tool is maintained.
- b) Never service damaged battery packs. Service of battery packs should only be performed by the manufacturer or authorized service providers.

POLE SAW SAFETY WARNINGS

- a) Use this pole saw only for the purposes it was designed, do not aim the pole saw at any people or animals.
- b) Remove the plug during transportation and during storage.
- c) Store pole saw indoors – when not in use, pole saw should be stored indoors in dry, locked-up place – out of reach of children.
- d) Always inspect the tool before

- use, and after any impact, check for sign of wear or damage and repair as necessary, especially the parts of the cutting head.
- e) Never use the product standing on steps or a ladder. Do not work over shoulder height.
 - f) Interrupt your work when you feel tired or exhausted. Make regular breaks to regenerate. A moment of inattention while operating the product may result in serious personal injury.
 - g) Do not use machine when the operator is tired, ill or under the influence of alcohol or other drugs.
 - h) Use slip-resistant foot protection as well as close-fitting clothes.
 - i) Keep all parts of the body away from the saw chain. Do not remove cut material or hold material to be cut when saw chain is moving. Make sure the switch is off when clearing jammed material. A moment of inattention while operating the product may result in serious personal injury.
 - j) Keep all parts of the body away from the saw chain when the product is operating.
 - k) Before you start the product, make sure the saw chain is not contacting anything. A moment of inattention while operating products may cause entanglement of your clothing or body with the saw chain.
 - l) Always hold the product with both hands on the handle and soft grip. Holding the product with only one hand or on parts not intended for that increases the risk of personal injury and should never be done.
 - m) Wear safety glasses and hearing protection. Further protective equipment for head, hands, legs and feet is recommended. Adequate protective clothing will reduce personal injury by flying debris or accidental contact with the saw chain.
 - n) Do not operate a product in a tree. Operation of a product while up in a tree may result in personal injury.
 - o) Always keep proper footing and operate the product only when standing on fixed, secure and level surface. Slippery or unstable surfaces such as ladders may cause a loss of balance or control of the product.
 - p) Carry the product by the soft grip with the product switched

off and away from your body. When transporting or storing the product always fit the guide bar cover. Proper handling of the product will reduce the likelihood of accidental contact with the moving saw chain.

- q) Follow instructions for lubricating, chain tensioning and changing accessories. Improperly tensioned or lubricated chain may either break or increase the chance for kickback.
- r) Keep handles dry, clean, and free from oil and grease. Greasy, oily handles are slippery causing loss of control.
- s) Cut wood only. Do not use product for purposes not intended. For example: do not use product for cutting plastic, masonry or non-wood building materials. Use of the product for operations different than intended could result in a hazardous situation.
- t) Pay attention to national and local regulations. National and local regulations may restrict the use of this product.
- u) Only use replacement guide bars and saw chains specified by the manufacturer or equivalent

replacements. Using non-approved cutting attachments can result in personal injuries and damage to property.

- v) Before using the product and after any impact or dropping, check for signs of wear or damage and repair as necessary.
- w) Carry out cleaning and maintenance works before storage of the pruner.

CAUSES AND OPERATOR PREVENTION OF KICKBACK

- a) Kickback may occur when the nose or tip of the guide bar touches an object, or when the wood closes in and pinches the saw chain in the cut.
- b) Tip contact in some cases may cause a sudden reverse reaction, kicking the guide bar up and back towards the operator.
- c) Pinching the saw chain along the top of the guide bar may push the guide bar rapidly back towards the operator.
- d) Either of these reactions may cause you to lose control of the saw which could result in serious personal injury. Do not rely exclusively upon the safety

devices built into your saw.

As a product user, you should take several steps to keep your cutting jobs free from accident or injury. Kickback is the result of tool misuse and/or incorrect operating procedures or conditions and can be avoided by taking proper precautions as given below:

- Maintain a firm grip, with thumbs and fingers encircling the product handles, with both hands on the saw and position your body and arm to allow you to resist kickback forces. Kickback forces can be controlled by the operator, if proper precautions are taken. Do not let go of the product.
- Do not overreach. This helps prevent unintended tip contact and enables better control of the product in unexpected situations.
- Only use replacement bars and chains specified by the manufacturer. Incorrect replacement bars and chains may cause chain breakage and/or kickback.
- Follow the manufacturer's maintenance instructions for the saw chain. Decreasing the depth gauge height can lead to increased kickback.

SAFETY WARNINGS FOR BATTERY PACK

- a) Do not attempt to recharge a non-rechargeable battery pack.
- b) Do not disassemble or modify the battery pack. This can damage safety features.
- c) Do not connect the positive (+) and negative (-) terminals with metal objects or store the battery pack with metal objects such as coins or screws. This can cause short-circuiting and generate enough heat to cause burns.
- d) Do not incinerate the battery pack or expose to excessive heat. This can melt insulation or damage safety features.
- e) Do not use, charge, or store near heat higher than 104°F (40°C). This can cause overheating and internal short-circuiting.
- f) Do not expose to extremely wet conditions. This can damage safety features, cause extremely high current and voltage charging, and lead to abnormal chemical reactions.
- g) Use only the charger specifically designed for the battery pack, and follow the safety precautions described in "Charger Safety". Using another charger can

damage safety features, cause extremely high current and voltage charging, and lead to abnormal chemical reactions.

- h) Do not strike, pierce, or throw the battery pack, and do not use a damaged or deformed battery pack.
- i) If recharging fails, do not attempt to recharge.
- j) If the battery pack gives off an odor, generates heat, or is discolored, deformed, or abnormal in any way during use, recharging, or storage, immediately remove from the chainsaw or charger.
- k) Any liquid leaking from the battery is corrosive, can damage eyes and skin, and may be toxic if swallowed.
- l) Do not dispose of the battery pack in the household waste or fire. Lithium ion battery packs should be recycled by a local authorized recycler.

SAFETY WARNINGS FOR BATTERY CHARGER



Read all safety warnings and instructions before using the charger.



Only for indoor use!



Class II protection.

- a) This appliance can be used by children aged from 8 years and above and persons with reduced physical, sensory or mental capabilities or lack of experience and knowledge if they have been given supervision or instruction concerning use of the appliance in a safe way and understand the hazards involved. Children shall not play with the appliance. Cleaning and user maintenance shall not be made by children without supervision.
- b) If the supply cord is damaged, it must be replaced by the manufacturer, its service agent or similarly qualified persons in order to avoid a hazard.
- c) Only charge the battery pack as specified in this instruction manual. Do not charge non-rechargeable batteries.
- d) Charge the product indoors only.
- e) Protect the charger against

moisture and wet conditions.
There is a danger of electric shock.

- f) Do not cover the battery charger. Otherwise, the battery charger can overheat and no longer operate properly.

INTENDED USE

This 18V pole saw is only intended to cut limbs with a thickness of max. 160 mm. It is only intended for outdoor use. It must not be used for cutting other materials, such as plastic, stone, metal or wood that contains foreign objects. Do not use it for other purposes.

RESIDUAL RISKS

- Familiarise yourself with the use of this product by means of this instruction manual. Memorise the safety directions and follow them to the letter. This will help to prevent risks and hazards. Always be alert when using this product, so that you can recognise and handle risks early. Fast intervention can prevent serious injury and damage to property. Switch off and disconnect from the battery if there are malfunctions.
- Even if all instructions are strictly followed, there are still some

factors that could lead to hazards, such as :

- Thrown out pieces of the work piece.
- Injuries and damage to property due to broken accessories or the sudden impact of hidden objects during use.
- Vibration injuries: use designated handles and try to reduce working time and exposure.
- Injuries caused by noise: wear ear protection and reduce working time and exposure.
- Inhalation of dust and particles.
- Wear eye protection at all times.
- If you experience any of these factors while using the machine, stop the machine consult your doctor immediately
- Injuries may be caused or aggravated by prolonged use of a tool. When using any tool for prolonged periods, ensure you take regular breaks.
- Prolonged use of the product exposes the user to vibrations that can cause a range of conditions collectively known as hand-arm vibration syndrome (HAVS) e.g. fingers going white; as well as specific diseases such as carpal tunnel syndrome.
- To reduce this risk when using the

product, always wear protective gloves and keep your hands warm.

 **WARNING!**

This unit produces an electromagnetic field during operation. This field may, under some circumstances, interfere with active or passive medical implants. To reduce the risk of serious or fatal injury, we recommend persons with medical implants to consult their physician and the medical implant manufacturer before operating this unit.

KNOW YOUR UNIT

APPLICATIONS

Model: CSPX2-M

As a pole saw:

Cutting limbs with a thickness of max. 6.4in.

1	Guide Bar
2	Saw Chain
3	Sprocket Cover Nut
4	Tensioning Gear
5	Sprocket Cover
6	Angle Adjustment Button
7	Pole
8	Connecting Sleeve
9	Telescoping Lock Clip
10	Front Handle
11	Safety Switch
12	Switch Trigger
13	Rear Handle
14	Battery Pack

SPECIFICATIONS*





NOTE:

CSPX2-M-0 does not include the charger and the battery pack.

Model	CSPX2-M
Input voltage	18V d.c.
No-load speed	3000rpm
Oil tank capacity	60ml
Chain speed	5.2m/s
Guide bar length	20cm
Cutting length(Max)	180mm
Collapsing Length	2.03-2.52m
Weight (without battery)	Approx. 3.0kg

Sound pressure level	80dB(A), K=3dB(A)
Measured sound power level	92.9dB(A), K=0.76dB(A)
Declared sound power level	95dB(A)
Vibration level(K=1.5 m/s ²)	Rear handle: 3.0< m/s ² Front handle: 3.3< m/s ²

Battery pack model for option	B20X2
Rated voltage	18V  , 20V Max.
Rated capacity	2.0Ah
Weight	Approx. 0.335kg
Battery pack model for option	B40X2
Rated voltage	18V  , 20V Max.
Rated capacity	4.0Ah
Weight	Approx. 0.65kg

Charger model for option	CHX2
Rated input	100-240V ~ 50/60Hz
Rated output	21V, 2A
Charging time (with 2.0 Ah battery)	75mins
Charging time (with 4.0 Ah battery)	140mins
Protection class	□ / II
Weight	Approx. 0.34kg
Charger model for option	CHQX2
Rated input	100-240V ~ 50/60Hz
Rated output	21V, 4A
Charging time (with 2.0 Ah battery)	35mins
Charging time (with 4.0 Ah battery)	70mins
Protection class	□ / II
Weight	Approx. 0.482kg
Optimal charging temperature	20°C–25°C

NOISE/VIBRATION INFORMATION

The declared vibration total value(s) and the declared noise emission value(s) have been measured in accordance with a standard test method and may be used for comparing one tool with another. They may also be used in a preliminary assessment of exposure.



WARNING:



The vibration and noise emissions during actual use of the power tool can differ from the declared values depending on the ways in which the tool is used especially what kind of workpiece is processed. It is necessary to identify safety measures to protect the operator that are based on an estimation of exposure in the actual conditions of use (taking account of all parts of the operating cycle such as the times when the tool is switched off and when it is running idle in addition to the trigger time).

Please try to minimize the exposure of vibration and noise. Typical measure for reducing exposure will be wearing of hand gloves and hearing protection during operation, limiting working time and applying accessories in good condition.

ASSEMBLY

1. Unpack all parts and lay them on a flat, stable surface:
2. Remove all packing materials and shipping devices, if applicable.
3. The scope of delivery varies depending on the country and purchased variant:
Model of CSPX2-M
 - Pole saw x1
 - Instruction manual x1
 - Guide bar x1
 - Guide bar cover x1
 - Saw chain x1
 - Wrench x1
 - Harness x1
 - Battery pack x1
 - Charger x1
4. If you find that parts are missing or show damage do not use the product but contact your dealer. Using an incomplete or damaged product represents a hazard to people and property.
5. Ensure that you have all the accessories and tools needed for assembly and operation. This also includes suitable personal protective equipment.



NOTE:

CSPX2-M-0 does not include the charger and the battery pack.



WARNING:

Wear protective gloves for this assembly work and always lay the product on a flat and stable surface while assembling.



Follow the assembly instructions step-by-step and use the pictures provided as a visual guide to easily assemble the product!



Do not insert the battery pack before the power tool is completely assembled or adjusted!

CONNECTING THE FRONT AND THE REAR POLE

1. Align arrows on the rear pole component and the front pole, then Insert for connecting (Fig.2).
2. Rotate the connecting sleeve clockwise to reinforce the connection (Fig.3).
3. Check looseness between two parts.

INSTALLING THE SAW CHAIN AND GUIDE BAR



WARNING:

Switch off and remove the battery pack before installing the saw chain and guide bar.

1. Loosen the sprocket cover nut and detach the chain sprocket cover (Fig.4).
2. Wind the saw chain to the outside edge of the guide bar. Make sure the chain teeth are stuck into the slots (Fig.5).



NOTE:

Make sure the chain's direction of rotation is correct. The blades on each cutting link on the upper side of the cutting bar must be facing towards the tip of the pole saw.

3. Attach the guide bar and the saw chain to the product. Loop the saw chain around the sprocket and locate the chain bar by the fixing bolt on the saw (Fig.5). If the guide bar and saw chain can not be mount over the drive sprocket, slightly adjust the tensioning gear.
4. Pull the chain around the guide bar with your gloved hand or using auxiliary tools to make sure it can run

- smoothly.
- Replace the sprocket cover and preliminarily screw the sprocket cover nut to prevent the guide bar and saw chain from dropping. Do not totally tighten it (Fig.4).
 - Turn the saw chain tensioning gear clockwise till the saw chain can be lifted by 2-3 mm from the center of the guide bar (Fig.5).
 - Fully tighten the sprocket cover nut to secure the sprocket cover.

INSTALLING THE HARNESS

The harness with quick release function can be hooked on the front handle (Fig.6).

BAR AND CHAIN OIL FILLING



WARNING:

Never operate the pole saw without bar and chain oil. The use of the pole saw without enough bar and chain oil will damage the unit.

This pole saw is shipped without bar and chain oil in the tank. Fill the oil tank for the initial use and check the oil level before every start.

- Place the pole saw on a level surface. Clean the area around the oil tank cap and then open it.
- Fill the oil tank with bar and chain oil carefully. Make sure that no dirt gets into the oil tank so that the oil nozzle does not clog.
- Close the oil tank cap and wipe off residual oil around the opening.

INSTALLING/REMOVING THE BATTERY PACK

To install:

Align and slide the battery pack to the docking port on the pole saw until it is locked in position (Fig.7).

To remove:

Press the unlock button on battery pack and remove the battery pack from the pole saw (Fig.8).

OPERATION



WARNING:

To avoid serious personal injury, do not operate the pole saw without the guide bar, saw chain and sprocket cover properly assembled. Do not attempt to operate the pole saw if any part is damaged or missing.



WARNING:

Always wear protective equipments. Make sure the pole saw is in a complete stop when perform any adjustments.

ADJUSTING THE SAW HEAD

The angle of the saw's head can be adjusted from -60° to 60° by pressing the angle adjustment button. Five stages (-60°, -30°, 0°, 30°, 60°) in total can be achieved (Fig.9). If you would like to change the angle of the saw's head, switch off the product and remove the battery pack at first in case of injury.

Make sure it is firmly engaged once adjusted. Never start the pole saw whose head is disengaged.

ADJUSTING POLE LENGTH

- Unlock the telescoping lock clip so that the pole can freely extend outwards and inwards (Fig.10).
- Extend the pole to the desired length and lock the telescoping lock clip to hold it in place (Fig.11).
- In order to prevent accident or injury, check the tightness by holding and stretching the both ends of the telescoping part.
- If the locked telescoping lock clip can not firmly hold the pole. The lock nut for the telescoping release lever is supposed to be tightened by a wrench.

ADJUSTING THE TENSION OF SAW CHAIN



WARNING:

After using, the chain tension may loose. Adjust the chain tension before next work.

If adjustments are needed, slightly loosen the sprocket cover nut. It's not necessary to remove the sprocket cover. Adjust the saw chain tensioning gear by a wrench. Do not over-tension the chain: this will lead to excessive wear and reduce the life of both the bar and chain.

Secure the sprocket cover nut after adjustment.



NOTE:

The saw chain is correctly tensioned if it can be raised approximately 2-3 mm from the center of the guide bar.

ADJUSTING THE HARNESS

Adjust the harness to a suitable length (Fig.12).

Always use the harness to carry the product weight on your shoulder (on the same side of tool or cross your body).

Ensure that the quick release is on your chest (NOT on your back). Open the quick release clamp under emergencies to take off the harness quickly (Fig.13).

SWITCHING ON/OFF



WARNING:

Before beginning work, you should check:

- The wearing of protective equipments.
- The damage of the saw housing, the saw chain and the guide bar.
- The level of the oil tank.
- The tension of the chain and the condition of the blades.

Hold the product as in working condition.

To start the product, keep pressing the safety switch, Then squeeze the switch trigger (Fig.14).

To switch the product off, just release the switch trigger.

CHARGING THE BATTERY PACK



WARNING:

This Lithium-Ion battery pack is shipped partially charged. Fully charge the battery pack before using it for the first time.

1. Charge the Lithium-Ion battery pack only with the correct charger.
2. Connect the charger to a power supply, the light indicator of the charger turns red.
3. Align the raised ribs of the battery pack with the slot in the charger.
4. Insert the battery pack into the charger, the light indicator of the charger turns green and it flashes (Fig.15).
5. The charger will communicate with the battery pack to evaluate the condition of the battery pack.
6. It is fully charged that the four lights of the battery turn

on. Disconnect the power supply from the charger.

Remove battery pack from the charger.

CHARGING INDICATOR

Press the light button on the battery pack to check whether it needs to charge (Fig.8).

Lights			Status
Lighted	Off	Blinking	
			The battery is at full capacity.
			The battery is at 75% capacity.
			The battery is at 50% capacity and requires charging.
			The battery is at 25% capacity and requires charging soon.
			The battery is less than 5% capacity and requires charging immediately.



WARNING:

Malfunctions may occur when the four lights blinking in turns.

OVERHEAT PROTECTION

When the tool/battery is overheated, the tool stops automatically. In this situation, let the power tool/battery cool before turning the tool on again.

OVERDISCHARGE PROTECTION

When the battery capacity is not enough, the tool stops automatically. In this case, remove the battery from the tool and charge the battery.

HOLDING THE UNIT

- Stand in the operating position and stand up straight. Do not bend over.
- Keep feet apart and firmly planted.
- Hold the shaft grip with the right hand. Keep the right arm slightly bent.
- Hold the handle with the left hand. Keep the left arm straight.
- Hold the unit at waist level.
- Position the cutting head a few inches above the ground.
- Do not over-reach; Keep all parts of your body away from the rotating cutting attachment and hot surfaces.

HANDLING POLE SAW

- Hold the pole saw with both hands.
- Wear the harness to carry the weight for maintain a better control of the product.
- Fully grip both handles at all times during operation. Never operate pole saw using only one hand.
- Hold the pole saw at a max. angle of 60° from the horizontal level (Fig.16).
- Do not stand directly under the limb you are sawing. Objects may fall different than expected. Position yourself well out of the path of falling limbs.
- Keep bystanders away from cutting end of garden power tool and a safe distance from the work area. Maintain a minimum distance of thirty feet to bystanders.
- Do not stand on a ladder or other support while using pole saw. Maintain a firm footing and balance during operation.
- Make sure the power cord is located to the rear, away from the chain and wood, and kept free of branches during cutting.
- Hold the pole saw to the side of your body.
- Do not operate the pole saw with arms fully extended or attempt to saw areas that are difficult to reach.
- Keep a firm, steady pressure on the pole saw while working. Do not try to force the pole saw through the wood, let the chain do the work. Use the gripping teeth to apply minimal leverage pressure.
- Use caution when reaching end of cut. The pole saw's weight may change unexpectedly as it cuts free from the wood. Always remove the pole saw from a wood cut while it is running.

AVOIDING KICKBACK DURING USE

Kickback occurs when the chain (at the tip of the guide bar) comes in contact with a log or wood, or when the saw chain becomes jammed, often when sawing sideward, slanted or during lengthwise cuts.

To avoid kickback:

- Saw with guide bar at a flat angle
- Do not work with a loose, overstretched or worn out chain
- Ensure chain is sharpened correctly
- Do not work with the tip of the guide bar
- Hold the pole saw firmly with both hands
- Use a low kickback chain
- Ensure correct chain tension

CUTTING THIN BRANCHES

- Thin branches can be cut off with a single cut.
- To prevent the branch from slivering and buckling, cut the branch off in several pieces (Fig.17). When cutting larger branches, the following four cuts are necessary:
- First cut into the branch from below, outside of the location where you intend to cut off the branch.
- The cut should go one third to halfway through the branch (1) (Fig.18).
- Cut into the branch from the top, making sure it's outside from where the branch is to be sawed (2) (Fig.18).
- To keep stump and branch from splintering, do a stub undercut below branch (3) (Fig.18).
- Cut off the stump with one clean cut from top to bottom. If desired, seal the cut with a suitable compound (4) (Fig.18).
- When finished cutting, turn off the pole saw and disconnect its power supply after use.
- Clean, then store the appliance indoors out of children's reach.

SAFE WORK



WARNING:

Do not operate near electrical power lines. The unit has not been designed to provide protection from electric shock in the event of contact with overhead electric lines, Consult local regulations for safe distances from overhead electric power lines and ensure that the operating position is safe and secure before operating the tool.

- Before beginning work and after dropping or other impacts, inspect the pole saw in order to identify any significant damage to the housing, the saw chain and the guide bar. Never use an obviously damaged machine.
- Before beginning work and regularly during work check oil level, lubrication system and chain tension.
- Wear hearing protection and protective goggles and a safety helmet with integrated hearing protection and a face guard. This provides protection against falling branches and recoiling branches.

- In order to ensure safe work, a maximum working angle of 60° is prescribed.
- Never stand below the branch to be sawed.
- Exercise caution when sawing branches under tension or splintering wood.
- Potential risk of injury from falling branches and flying wood projectiles!
- If the machine is in operation, keep persons and animals away from the danger area.
- The machine is not protected against electric shock when coming into contact with high-voltage lines.
- Maintain a minimum clearance of 30 feet (10 m) from current carrying lines. Life-threatening danger from electric shock!
- When working on an incline, always stand above or to the side of the branch to be sawed.
- Hold the machine as close as possible to your body. By doing so, you maximize your balance. Make absolutely sure to wear the appropriate, close fitting protective clothing, such as chainsaw-protective pants, gloves and safety shoes.
- Never overwork yourself. Take a regular rest during working.

SAWING TECHNIQUES



WARNING:

The risk of the operation may occur, such as the sharp tree branches may cut the user's skin, the blade of the unit may hurt the user's body. Always wear eye, hearing, hand, foot and body protection to reduce the risk of injury when operating this unit.

- Make sure the chain is running at full speed before touching the branch to be cut
- When removing branches, hold the pole saw at an angle ranging from 0 to 60° in order to avoid being struck by a falling branch. The saw should never be operated directly above head.
- Saw off the lower branches on the tree first. By doing so, it is easier for the cut branches to fall to the ground.
- At the end of the cut, the weight of the saw suddenly increases for the user, because the saw is no longer supported on the branch. There is the risk of losing control of the saw.
- Only pull the saw out of the cut with the saw chain running. By doing so, you can prevent it from getting jammed.
- Do not saw with the tip of the guide bar.
- **IMPORTANT!** Use the shoulder strap! Always use the shoulder strap when working with the equipment. Switch off the equipment before you take off the shoulder strap (risk of injury). And hold the pole saw firmly with both

hands.

- If any foreign object is hit or if vibrations occur, stop the machine immediately. Disconnect the battery. Check that the machine is not damaged. Repair any damage.
- For sawing off smaller branches, place the stop face of the saw on the branch. This prevents unwanted movements of the saw at the beginning of the cut. While applying light pressure, guide the saw through the branch from top to bottom.
- For sawing off larger branches, first make a relief cut. Saw through 1/3 of the branch diameter from the bottom to top using the top side of the guide bar. Then saw from top to bottom for the other 2/3 using the bottom side of the guide bar.
- Saw off longer branches in sections in order to maintain control over the location of impact.

MAINTENANCE



WARNING:

Always remove the battery pack and let the product completely cool down before performing cleaning and maintenance work!

Always wear protective equipments such as gloves and eye protections to reduce the risk of injury when operating this unit.

Only perform cleaning and maintenance work according to these instructions! All further works must be performed by a qualified specialist!

When servicing use only identical replacement parts. Use of any other accessory or attachment may increase the risk of injury.

REPLACING THE SAW CHAIN AND GUIDE BAR



WARNING:

When handling saw chains, always wear protective gloves.

Replace chain when cutters are too worn to sharpen or when chain breaks. Only use replacement chain noted in this manual. **DO NOT** use any other bar/chain combination. Always include new drive sprocket when replacing chain. This will maintain proper driving of chain.

1. Place the pole saw body on a firm and level surface.
2. Loosen the sprocket cover nut to remove the chain sprocket cover.
3. Wearing protective gloves, take off the broken saw

chain or the guide bar.

4. Wind the new saw chain around the new guide bar, making sure that the teeth are aimed in the direction of rotation. The chain should be properly seated into the slot running along the entire outside edge of the guide bar.
5. Loop the saw chain around the sprocket and locate the guide bar by matching its hole with the fixing bolt on the saw.
6. Put the sprocket cover on the original place.
7. Screw the sprocket cover nut, but not tight.
8. Adjust the chain tension according to the chapter "ADJUSTING THE TENSION OF SAW CHAIN".
9. Fully tighten the sprocket cover nut to secure the sprocket cover.
10. Check for the smooth movement of the saw chain.

SHARPENING THE SAW CHAIN

Keep chain sharp. Your saw will cut more efficient and more safely. A dull chain will cause undue sprocket, guide bar, chain, and motor wear.

Do not force chain into wood to prevent the saw chain from becoming dull.



NOTE:

Do not sharpen the saw chain by yourself unless you are experienced in doing so. It is recommended to have the chain saw sharpened by an authorized service.



WARNING:

Switch off and remove the battery pack before servicing. Cutting edges on chain are sharp. Use protective gloves when handling chain.

To sharpen the chain:

1. Using protective gloves, ensure the chain is correctly tensioned on the guide bar.
 2. Use a round file with a diameter 1.1 times the cutting tooth depth. Make sure 20% of the file diameter is above the cutter's top plate (Fig.19).
 3. File at an angle perpendicular to the bar, and at an angle of 25° to the direction of travel (Fig.20).
 4. File each tooth from the inside towards outside only. File one side of the chain first then turn the saw around and repeat the process.
- Sharpen each tooth equally by using the same number of strokes.
 - Keep all cutter lengths equal. Each time the cutting tip is sharpened the cutting length is reduced. When the cutter length is reduced to 0.16 inch (4 mm), the chain is worn out and should be replaced.
 - The depth gauge setting is also reduced with each sharpening. Every 5 sharpenings use a depth gauge

measuring tool to check the height between the cutting tip and the ridge. When necessary, use a flat file to file down the ridge to achieve the 0.25 inch depth gauge setting. Depth gauge measuring tools are available from most pole saws retailers (Fig.21).

- If the saw is not functioning properly, take it to a qualified pole saw service center to have the saw inspected. Use only identical parts as listed in this manual.

CLEANING

- Remove debris from the saw chain and guide bar.
- Always clean out wood chips, saw dust and dirt from the guide bar's groove when replacing the chain.
- Ensure that the chain tensioning gear is free of wood chips and other debris.
- Use a small brush to clean the outside of the unit.
- Wipe power head with a clean cloth moistened with a mild soap solution. Never use harsh cleaners or solvents.
- Remove wood chips and other debris from air vents.
- Clean dirty contacts with a soft, dry cloth. Dirt or oil can cause a poor electrical connection, resulting in loss of power.

TRANSPORT

- Remove the battery pack from the pole saw.
- Clean the product as described above.
- Install a guide bar cover.
- Always carry the product by its handle.
- Protect the product from any heavy impact or strong vibrations which may occur during transportation in vehicles.
- Secure the product to prevent it from slipping or falling over, damage or injury.

STORAGE

- Remove the battery pack from the pole saw.
- Clean the product as described above.
- Store the product and its accessories in a dark, dry, frost-free, well-ventilated place.
- Always store the product in a place that is inaccessible to children.
- We recommend using the original package for storage or covering the product with a suitable cloth or enclosure to protect it against dust.



NOTE:

To prolong battery life, never store battery pack in a completely discharged condition. Make sure the battery pack is charged once per year or when the LED indicator shows only one light.

TROUBLESHOOTING

Suspected malfunctions are often due to causes that the users can fix themselves. Therefore, check the product using this section. In most cases the problem can be solved quickly.

PROBLEM	POSSIBLE CAUSE	SOLUTION
Product does not start	Battery pack not properly attached	Attach properly
	Battery pack capacity too low	Remove and charge battery pack
	Battery pack damaged	Check by a specialist electrician
	Safety switch is not turned on	Refer to chapter "SWITCHING ON/OFF"
Product does not reach full power	Battery pack capacity too low	Charge battery pack
	Air vents are blocked	Clean the air vents
Result is unsatisfactory	Cutting attachment is worn	Replace with a new one
Vibration or noise is excessive	Bolts/nuts are loose	Tighten bolts/nuts
Product suddenly stops	Battery pack capacity too low	Remove and charge battery pack
	Battery too hot	Remove battery pack and let it cool down

RECYCLING AND DISPOSAL



Disposal of waste electric and electronic equipment (WEEE)

Waste electric and electronic equipment shall not be disposed of with household waste. Please recycle where facilities exist. Check with your local authority for recycling advice.



Disposal of defective or used battery pack
 Discharge your battery pack by operating your tool, then remove the battery pack from the tool. Cover the battery pack connections with heavy duty adhesive tape to prevent short circuit and energy discharge.
 Do not attempt to open or remove any of the components.
 Batteries and battery packs shall not be disposed of with household waste. Consult your local waste authority for information regarding available recycling and/or disposal options.

PARTS

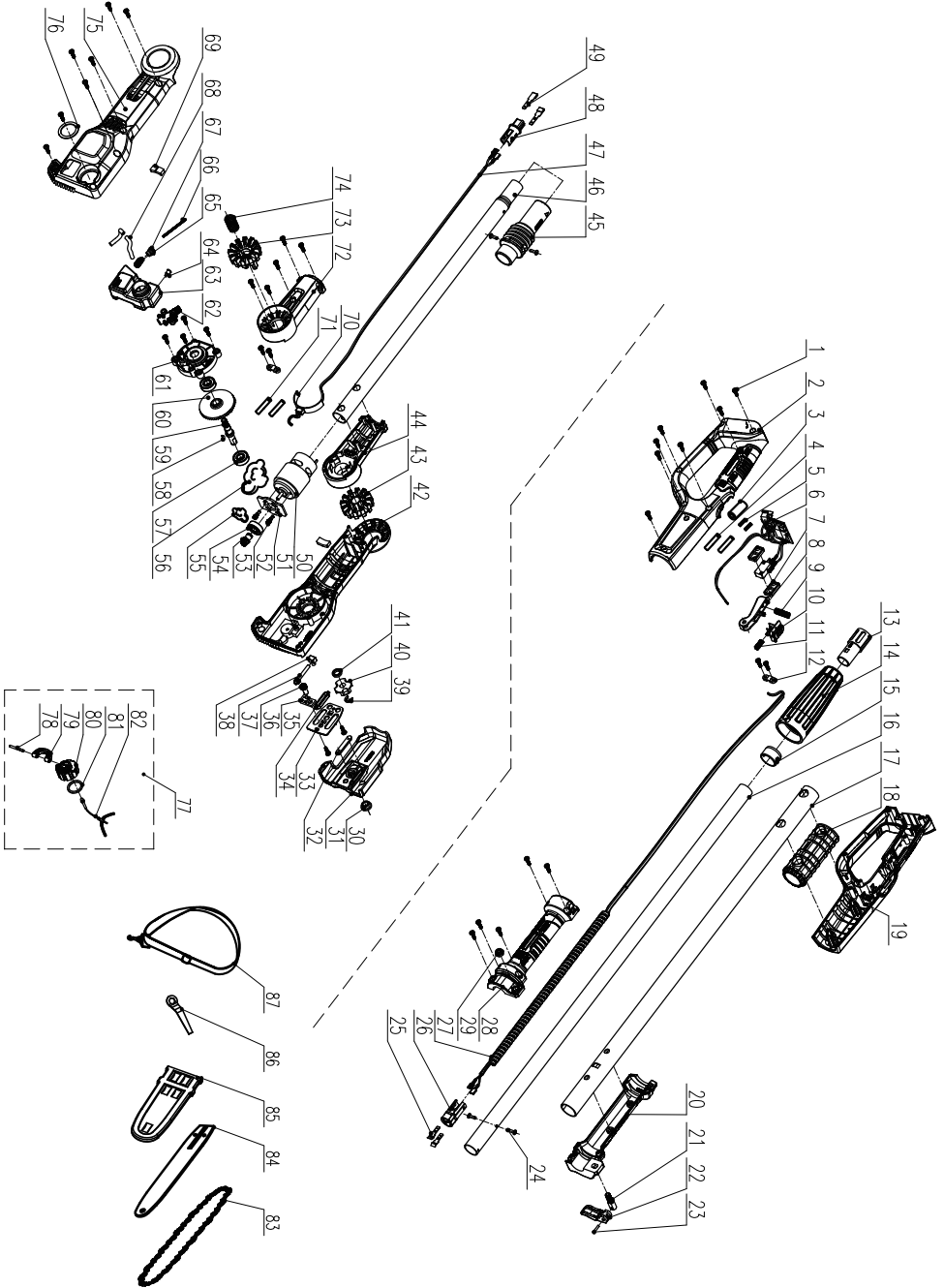

No.	Parts #	Description	Qty.
1	8SJGB40-16	Compound groove pan head tapping screw	35
2	A044004-005-00	Housing	1
3	8415-740803-00	Magnetic ring	1
4	233-1004	Heat shrinkable tube	0.1m
5	239-0044	Copper strip	10
6	A014007-035-00	Electronic components	1
7	8341-530901-00	Switch pad	2
8	A044004-021-00	Trigger	1
9	8342-740201-00	Switch Spring	1
10	A043022-007-00	Safety switch	1
11	8342-534101-00	Spring	1
12	8184-302201-00	Cable pressing plate	2
13	A014007-015-00	Pole sleeve	1
14	A014007-010-00	Pole sleeve	1
15	A014007-012-00	Pole sleeve	1
16	A014007-026-00	Pole	1
17	A014007-025-00	Pole	1
18	A014007-016-00	Pole sleeve	1
19	A044004-004-00	Housing	1
20	A014007-008-00	Front handle	1
21	8206-650204-02	Quick clip adjusting bolt	1
22	8044-650203-01	Telescoping lock clip	1
23	8086-650204-00	Cylindrical pin	1
24	8RJ04-06D01	Open type oval head blind rivets	4
25	A014007-022-00	Contact sheet	2
26	A014007-014-00	Contact holder	1
27	A014007-028-00	Spring connecting wire	1
28	A014007-029-00	Front handle	1
29	8NE-08	All metal hexagon flange lock nut	2
30	8334-463101-00	Axle sleeve	1
31	A014007-004-00	Sprocket cover	1
32	8208-438801-00	Sprocket cover seal ring	1
33	A014007-023-00	Insulation gasket	1
34	A013004-013-00	Seal ring	1
35	A013021-027-00	Fixing plate	1
36	8123-965602-01	Gear	1
37	A013021-028-00	Screw	1
38	A013021-029-00	Nut	1
39	8CE-07B	E-type retaining ring	1
40	8128-462202-00	Sprocket	1
41	F022009-019-00	Axle sleeve	1
42	A014007-002-00	Housing	1
43	8312-531402-00	Angle adjustment button	1
44	A014007-006-00	Housing	1
45	A014007-011-00	Connecting sleeve	1

46	A014007-027-00	Pole	1
47	A014007-040-00	Connector assembly	1
48	A014007-013-00	Contact holder	1
49	A014007-021-00	Contact sheet	2
50	A014007-030-00	Motor	1
51	A014007-020-00	Motor bracket	1
52	8SJGN04-14	Composite groove pan head three combination drop resistant screw	2
53	A014007-032-00	Gear	1
54	8BC-261008-ST03	Deep groove ball bearing	2
55	242-1009	Thread locking compound	0.2g
56	8346-000012-00	Lubricating oil	10g
57	8BC-261008-SS	Deep groove ball bearing	1
58	8205-430601-00	Semicircular bond	1
59	A014007-033-00	Output shaft	1
60	A014007-031-00	Gear	1
61	A014007-005-00	Gearbox	1
62	A013003-022-00	Oil pump assembly	1
63	A014007-019-00	Oil tank	1
64	8335-481201-00	valve	1
65	8342-437501-02	conical compression spring	1
66	8342-000002-00	Oil tube setting spring	0.07m
67	A013004-040-00	Seal ring	1
68	234-1003	Transparent tubing	0.15m
69	A014007-024-00	Damping pad	2
70	8020-532701-00	Sliding plate	1
71	233-1008	Heat shrinkable tube	0.1m
72	A014007-007-00	Housing	1
73	8136-531401-00	Passive chuck	1
74	8342-521702-01	Angle adjustment button spring	1
75	A014007-003-00	Housing	1
76	8208-431901-01	Seal ring	1
77	A014005-007-00	Oil tank cap assembly	1
78	A013010-017-00	Cylindrical pin	1
79	A014005-010-00	Bracket	1
80	A014005-008-00	Oil tank cap	1
81	8341-491801-00	Rubber pad	1
82	8088-481501-01	Anti loss hook of oil tank cover	1
83	A014007-042-00	Saw chain	1
84	A014007-046-00	Guide bar	1
85	9331-T10701-00	Guide bar cover	1
86	8261-463101-00	Wrench	1
87	8214-430802-00	Harness	1

