

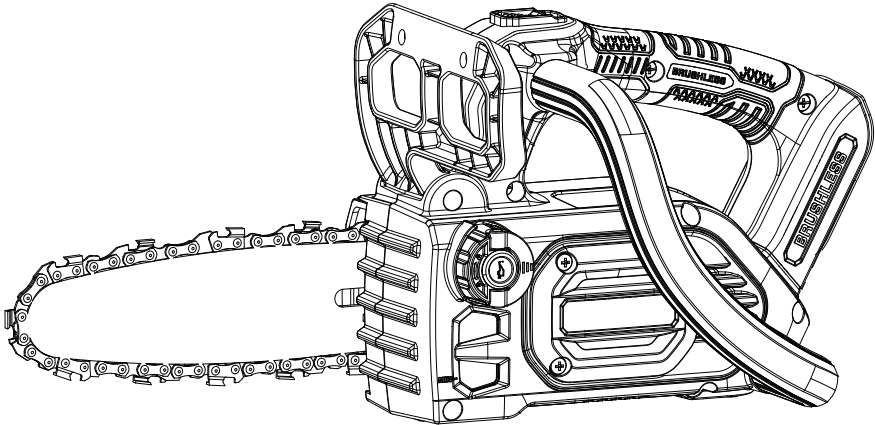

---

# 20V MAX LITHIUM ION CORDLESS CHAINSAW

Model: CSX2-M1  
CSX2-M1-0



For customer service please find all information on [www.senixtools.com](http://www.senixtools.com)  
CAUTION: BEFORE USING THIS PRODUCT, READ THIS MANUAL AND  
FOLLOW ALL ITS SAFETY RULES AND OPERATING INSTRUCTIONS.

ORIGINAL INSTRUCTIONS

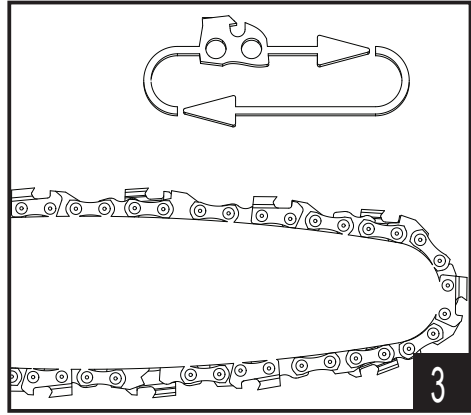
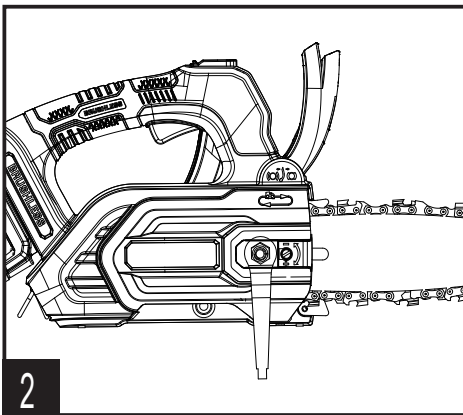
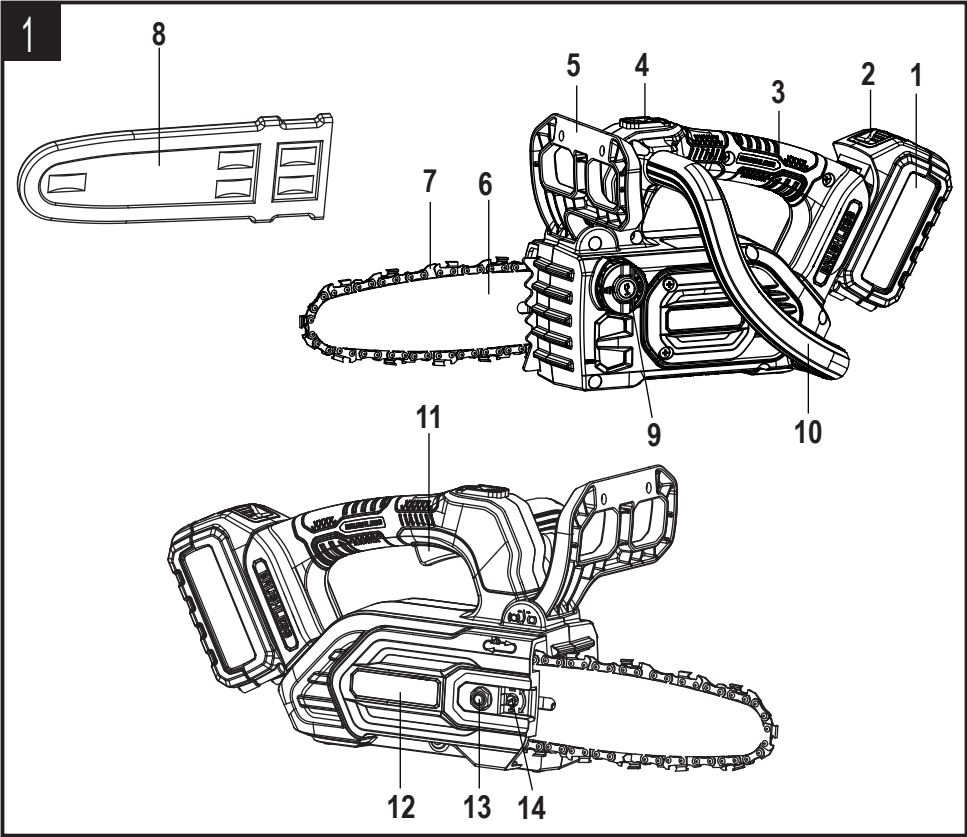

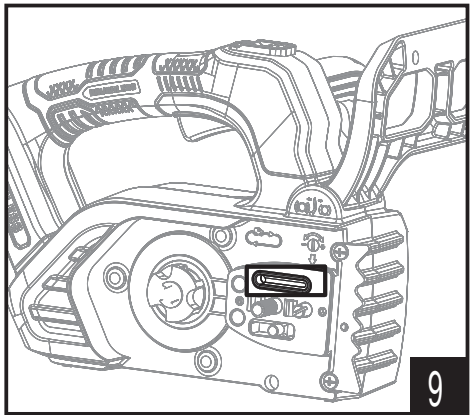
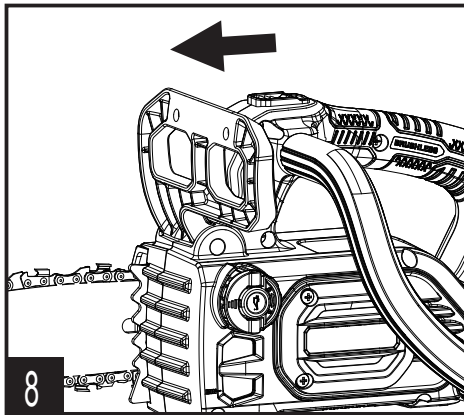
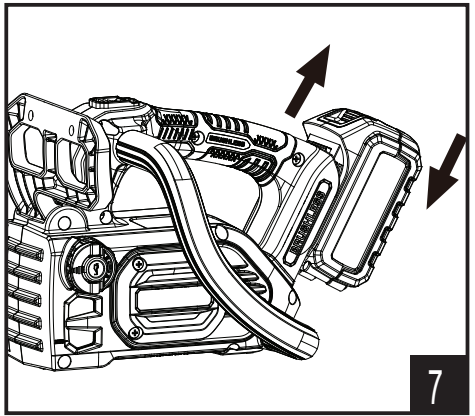
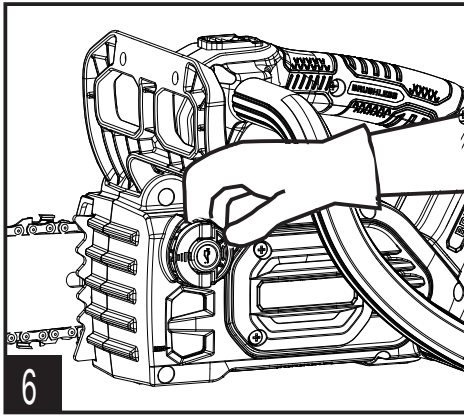
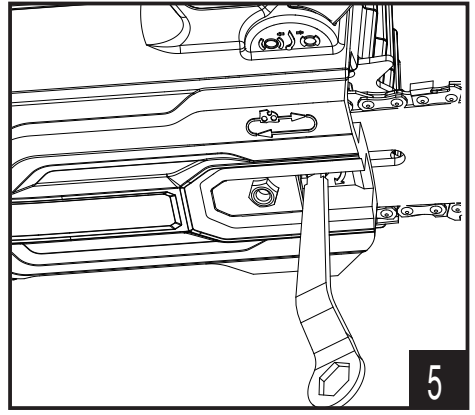
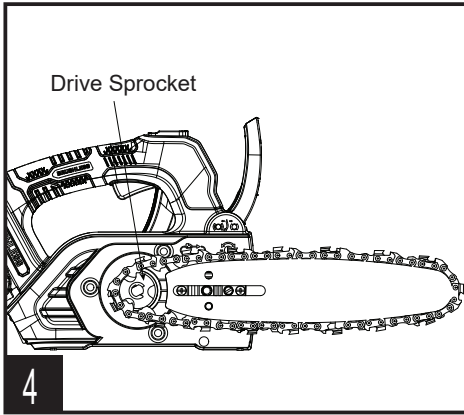

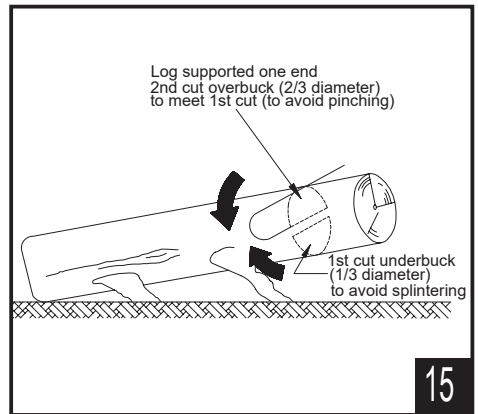
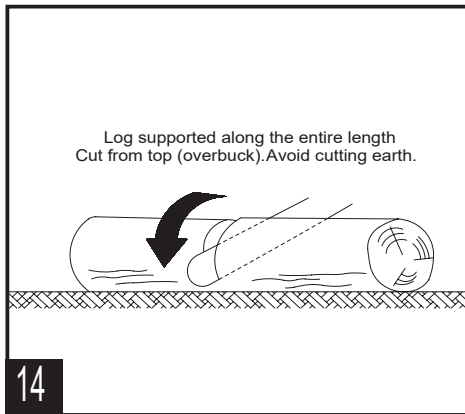
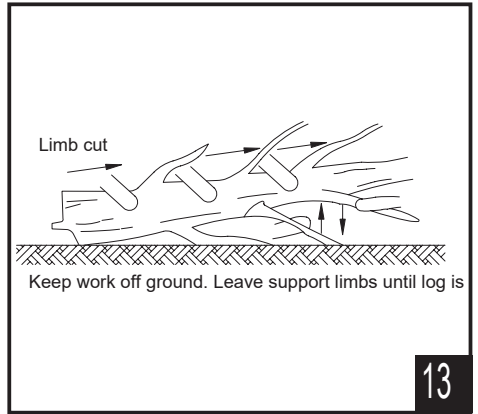
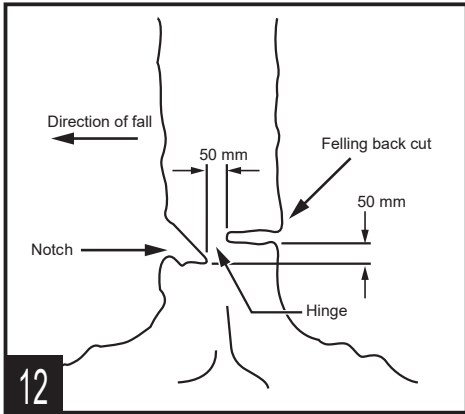
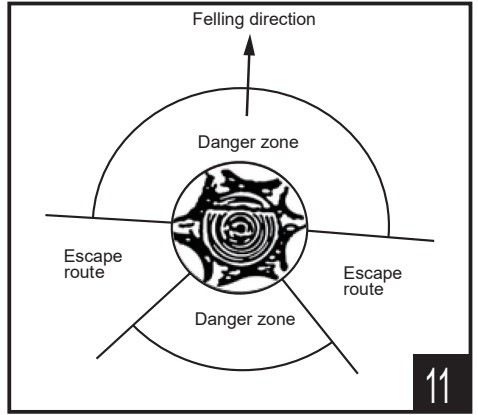
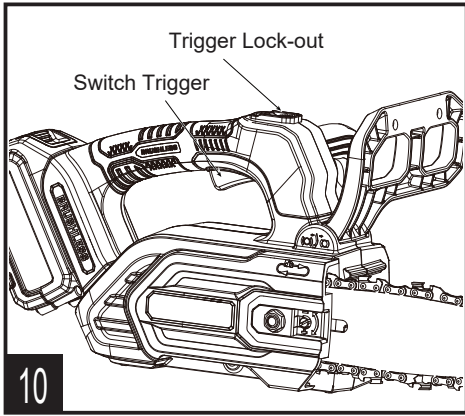

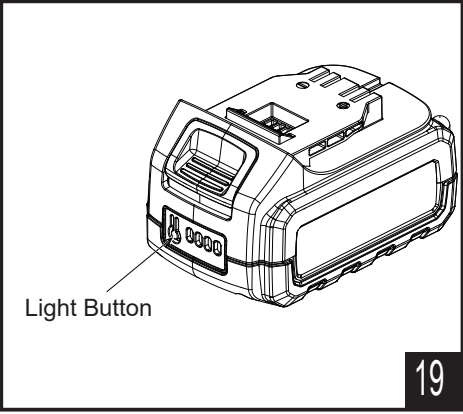
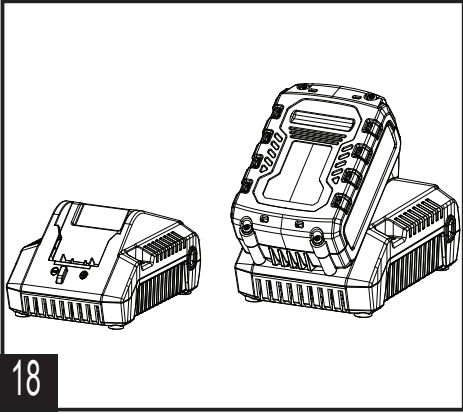
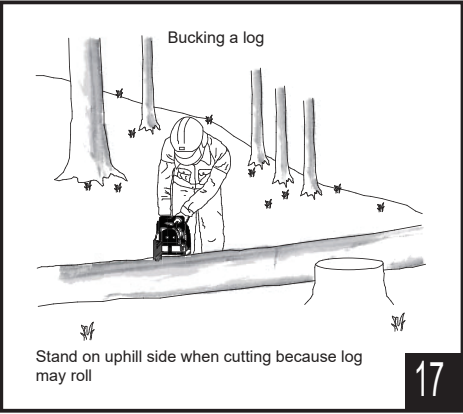
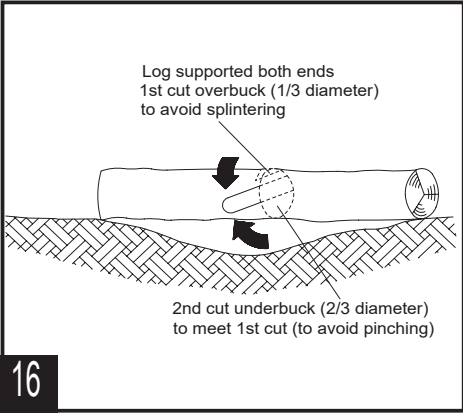











# TABLE OF CONTENTS

SAFETY & INTERNATIONAL SYMBOLS .....	6
SAFETY INSTRUCTIONS.....	7
KNOW YOUR UNIT.....	16
SPECIFICATIONS*.....	16
ASSEMBLY.....	17
OPERATION.....	18
MAINTENANCE.....	21
TROUBLESHOOTING.....	22
RECYCLING AND DISPOSAL.....	23
PARTS.....	24

# SAFETY & INTERNATIONAL SYMBOLS

Explanation of Safety & international symbols describes safety and international symbols and pictographs that may appear on this product. Read the operator's manual for complete safety, assembly, operating and maintenance and repair information.

-  Caution / Warning.
-  To reduce the risk of injury, user must read instruction manual.
-  Wear ear protection.
-  Wear protective gloves.
-  Wear eye protection and safety helmet.
-  Wear a dust mask.
-  Switch the product off and remove the battery pack to disconnect from the power supply before assembly, cleaning, adjustments, maintenance, storage and transportation.
-  Polarity symbol of charger jack output +/-
-  Do not dispose of battery packs in rivers or immerse in water.
-  Do not dispose of battery packs in fire. They will explode and cause injury.
-  Use and store the battery within a temperature below 50°C.



Do not expose to rain.



Kickback! Tip contact may cause the guide bar to move suddenly upward and backwards what may cause serious injury to user.



Beware of chain saw kickback and avoid contact with bar tip



Always use chain saw two-handed.



Objects thrown by the product could hit the user or other bystanders. Always ensure that other people and pets remain at a safe distance from the product when it is in operation. In general, children must not come near the area where the product is.



Correct direction of cutting-teeth



Chain oil fill



Chain brake (the  symbol shows the position in which the brake is released)



Do not disassemble, crush, heat above 100°C ; Never expose the battery to microwaves or high pressures.



This charger is of protection class II. That means it is equipped with enhanced or double insulation.



The product complies with the applicable European directives and an evaluation method of conformity for these directives was done.



WEEE symbol. Waste electrical products should not be disposed of with household waste. Please recycle where facilities exist. Check with your Local Authority or local store for recycling advice.



Crossed out dust bin. Batteries and battery packs should not be disposed of with household waste. Please recycle where facilities exist. Check with your Local Authority or local store for recycling advice.



Guaranteed sound power level value in 97 dB(A).

## **SAFETY INSTRUCTIONS**

### **GENERAL POWER TOOL SAFETY WARNINGS**

#### **WARNING!**

Read all safety warnings, instructions, illustrations and specifications provided with this power tool. Failure to follow all instructions listed below may result in electric shock, fire and/or serious injury.

Save all warnings and instructions for future reference.

The term "power tool" in the warnings refers to your mains-operated (corded) power tool or battery-operated (cordless) power tool.

#### **1) Work Area Safety**

- a) Keep work area clean and well lit. Cluttered or dark areas invite accidents.
- b) Do not operate power tools in explosive atmospheres, such as in the presence of flammable liquids, gases or dust. Power tools create sparks which may ignite the dust or fumes.
- c) Keep children and bystanders away while operating a power tool. Distractions can cause you to lose control.

#### **2) Electrical Safety**

- a) Power tool plugs must match the outlet. Never modify the plug in any way. Do not use any adapter plugs with earthed (grounded) power tools. Unmodified plugs and matching outlets will reduce risk of electric shock.
- b) Avoid body contact with earthed or grounded surfaces, such as pipes, radiators, ranges and refrigerators. There is an increased risk of electric shock if your body is earthed or grounded.
- c) Do not expose power tools to rain or wet conditions. Water entering a power tool will increase the risk of electric shock.
- d) Do not abuse the cord. Never use the cord for carrying, pulling or unplugging the power tool. Keep cord away from heat, oil, sharp edges or moving parts. Damaged or entangled cords increase the risk of electric shock.
- e) When operating a power tool outdoors, use an extension cord suitable for outdoor use. Use of a cord suitable for outdoor use reduces the risk of electric shock.

- f) If operating a power tool in a damp location is unavoidable, use a residual current device (RCD) protected supply. Use of an RCD reduces the risk of electric shock.

NOTE The term “residual current device (RCD)” can be replaced by the term “ground fault circuit interrupter (GFCI)” or “earth leakage circuit breaker (ELCB)”.

### 3) Personal Safety

- a) Stay alert, watch what you are doing and use common sense when operating a power tool. Do not use a power tool while you are tired or under the influence of drugs, alcohol or medication. A moment of inattention while operating power tools may result in serious personal injury.
- b) Use personal protective equipment. Always wear eye protection. Protective equipment such as a dust mask, non-skid safety shoes, hard hat or hearing protection used for appropriate conditions will reduce personal injuries.
- c) Prevent unintentional starting. Ensure the switch is in the off-position before connecting to power source and/or battery pack, picking up or carrying the tool. Carrying power tools with your finger on the switch or energising power tools that have the switch on invites accidents.
- d) Remove any adjusting key or wrench before turning the power tool on. A wrench or a key left attached to a rotating part of the power tool may result in personal injury.
- e) Do not overreach. Keep proper footing and balance at all times. This enables better control of the power tool in unexpected situations.
- f) Dress properly. Do not wear loose clothing or jewellery. Keep your hair and clothing away from moving parts. Loose clothes, jewellery or long hair can be caught in moving parts.
- g) If devices are provided for the connection of dust extraction and collection facilities, ensure these are connected and properly used. Use of dust collection can reduce dust-related hazards.
- h) Do not let familiarity gained from frequent use of tools allow you to become complacent and ignore tool safety principles. A careless action can cause



severe injury within a fraction of a second.

#### **4) Power Tool Use And Care**

- a) Do not force the power tool. Use the correct power tool for your application. The correct power tool will do the job better and safer at the rate for which it was designed.
- b) Do not use the power tool if the switch does not turn it on and off. Any power tool that cannot be controlled with the switch is dangerous and must be repaired.
- c) Disconnect the plug from the power source and/or remove the battery pack, if detachable, from the power tool before making any adjustments, changing accessories, or storing power tools. Such preventive safety measures reduce the risk of starting the power tool accidentally.
- d) Store idle power tools out of the reach of children and do not allow persons unfamiliar with the power tool or these instructions to operate the power tool. Power tools are dangerous in the hands of untrained users.
- e) Maintain power tools and

accessories. Check for misalignment or binding of moving parts, breakage of parts and any other condition that may affect the power tool's operation. If damaged, have the power tool repaired before use. Many accidents are caused by poorly maintained power tools.

- f) Keep cutting tools sharp and clean. Properly maintained cutting tools with sharp cutting edges are less likely to bind and are easier to control.
- g) Use the power tool, accessories and tool bits etc. in accordance with these instructions, taking into account the working conditions and the work to be performed. Use of the power tool for operations different from those intended could result in a hazardous situation.
- h) Keep handles and grasping surfaces dry, clean and free from oil and grease. Slippery handles and grasping surfaces do not allow for safe handling and control of the tool in unexpected situations.

#### **5) Battery Tool Use And Care**

- a) Recharge only with the charger specified by the manufacturer. A

charger that is suitable for one type of battery pack may create a risk of fire when used with another battery pack.

- b) Use power tools only with specifically designated battery packs. Use of any other battery packs may create a risk of injury and fire.
- c) When battery pack is not in use, keep it away from other metal objects, like paper clips, coins, keys, nails, screws or other small metal objects, that can make a connection from one terminal to another. Shorting the battery terminals together may cause burns or a fire.
- d) Under abusive conditions, liquid may be ejected from the battery; avoid contact. If contact accidentally occurs, flush with water. If liquid contacts eyes, additionally seek medical help. Liquid ejected from the battery may cause irritation or burns.
- e) Do not use a battery pack or tool that is damaged or modified. Damaged or modified batteries may exhibit unpredictable behaviour resulting in fire, explosion or risk of injury.
- f) Do not expose a battery pack or tool to fire or excessive

temperature. Exposure to fire or temperature above 130 °C may cause explosion.

- g) Follow all charging instructions and do not charge the battery pack or tool outside the temperature range specified in the instructions. Charging improperly or at temperatures outside the specified range may damage the battery and increase the risk of fire.

## **6) Service**

- a) Have your power tool serviced by a qualified repair person using only identical replacement parts. This will ensure that the safety of the power tool is maintained.
- b) Never service damaged battery packs. Service of battery packs should only be performed by the manufacturer or authorized service providers.

## **GENERAL CHAIN SAW SAFETY WARNINGS**

- a) Keep all parts of the body away from the saw chain when the chain saw is operating. Before you start the chain saw, make sure the saw chain is not contacting anything. A

- moment of inattention while operating chain saws may cause entanglement of your clothing or body with the saw chain.
- b) Always hold the chain saw with your right hand on the rear handle and your left hand on the front handle. Holding the chain saw with a reversed hand configuration increases the risk of personal injury and should never be done.
  - c) Hold the chain saw by insulated gripping surfaces only, because the saw chain may contact hidden wiring or its own cord. Saw chains contacting a "live" wire may make exposed metal parts of the chain saw "live" and could give the operator an electric shock.
  - d) Wear eye protection. Further protective equipment for hearing, head, hands, legs and feet is recommended. Adequate protective equipment will reduce personal injury from flying debris or accidental contact with the saw chain.
  - e) When cutting a limb that is under tension, be alert for spring back. When the tension in the wood fibres is released, the spring loaded limb may strike the operator and/or throw the chain saw out of control.
  - f) Use extreme caution when cutting brush and saplings. The slender material may catch the saw chain and be whipped toward you or pull you off balance.
  - g) Carry the chain saw by the front handle with the chain saw switched off and away from your body. When transporting or storing the chain saw, always fit the guide bar cover. Proper handling of the chain saw will reduce the likelihood of accidental contact with the moving saw chain.
  - h) Follow instructions for lubricating, chain tensioning and changing the bar and chain. Improperly tensioned or lubricated chain may either break or increase the chance for kickback.
  - i) Cut wood only. Do not use chain saw for purposes not intended. For example: do not use chain saw for cutting metal, plastic, masonry or non-wood building materials. Use of the chain saw for operations different than intended could result in a hazardous situation.

- j) Do not attempt to fell a tree until you have an understanding of the risks and how to avoid them. Serious injury could occur to the operator or bystanders while felling a tree.
- k) Follow all instructions when clearing jammed material, storing or servicing the chain saw. Make sure the switch is off and the battery pack is removed. Unexpected actuation of the chain saw while clearing jammed material or servicing may result in serious personal injury.

## **CAUSES AND OPERATOR PREVENTION OF KICKBACK**

Kickback may occur when the nose or tip of the guide bar touches an object, or when the wood closes in and pinches the saw chain in the cut.

Tip contact in some cases may cause a sudden reverse reaction, kicking the guide bar up and back towards the operator.

Pinching the saw chain along the top of the guide bar may push the guide bar rapidly back towards the operator.

Either of these reactions may cause you to lose control of the saw which

could result in serious personal injury. Do not rely exclusively upon the safety devices built into your saw.

As a chain saw user, you should take several steps to keep your cutting jobs free from accident or injury.

Kickback is the result of chainsaw misuse and/or incorrect operating procedures or conditions and can be avoided by taking proper precautions as given below:

- Maintain a firm grip, with thumbs and fingers encircling the chainsaw handles, with both hands on the saw and position your body and arm to allow you to resist kickback forces. Kickback forces can be controlled by the operator, if proper precautions are taken. Do not let go of the chainsaw.
- Only use replacement bars and saw chains specified by the manufacturer. Incorrect replacement bars and saw chains may cause chain breakage and/or kickback.
- Follow the manufacturer's sharpening and maintenance instructions for the saw chain. Decreasing the depth gauge height can lead to increased

- kickback.
- Do not rely exclusively upon the safety devices built into your saw. As a chainsaw user, you should take several steps to keep your cutting jobs free from accident or injury.

## **ADDITIONAL CHAIN SAW SAFETY WARNINGS**

- a) We recommend that the first-time users should, as a minimum practice, cutting logs on a saw-horse or cradle.
- b) The machine shall be used in a covered and dry area. The ambient temperature shall be included between 15°C and 30°C. The humidity level shall be less than 60%.

## **SAFETY WARNINGS FOR BATTERY PACK**

- a) Do not attempt to recharge a non-rechargeable battery pack.
- b) Do not disassemble or modify the battery pack. This can damage safety features.
- c) Do not connect the positive (+) and negative (-) terminals with metal objects or store the battery pack with metal objects such as coins or screws. This can cause short-circuiting and generate

- d) enough heat to cause burns.
- d) Do not incinerate the battery pack or expose to excessive heat. This can melt insulation or damage safety features.
- e) Do not use, charge, or store near heat higher than 40°C. This can cause overheating and internal short-circuiting.
- f) Do not expose to extremely wet conditions. This can damage safety features, cause extremely high current and voltage charging, and lead to abnormal chemical reactions.
- g) Use only the charger specifically designed for the battery pack, and follow the safety precautions described in "Charger Safety". Using another charger can damage safety features, cause extremely high current and voltage charging, and lead to abnormal chemical reactions.
- h) Do not strike, pierce, or throw the battery pack, and do not use a damaged or deformed battery pack.
- i) If recharging fails, do not attempt to recharge.
- j) If the battery pack gives off an odor, generates heat, or is discolored, deformed, or abnormal in any way during

- use, recharging, or storage, immediately remove from the chainsaw or charger.
- k) Any liquid leaking from the battery is corrosive, can damage eyes and skin, and may be toxic if swallowed.
  - l) Do not dispose of the battery pack in the household waste or fire. Lithium ion battery packs should be recycled by a local authorized recycler.

## SAFETY WARNINGS FOR BATTERY CHARGER



Read all safety warnings and instructions before using the charger.



Only for indoor use!



Class II protection.

- a) This appliance can be used by children aged from 8 years and above and persons with reduced physical, sensory or mental capabilities or lack of experience and knowledge if they have been given supervision or instruction concerning use of the appliance in a safe way and understand the hazards involved. Children shall not play with the appliance. Cleaning and user maintenance shall not be made by children without supervision.
- b) If the supply cord is damaged, it must be replaced by the manufacturer, its service agent or similarly qualified persons in order to avoid a hazard.
- c) Only charge the battery pack as specified in this instruction manual. Do not charge non-rechargeable batteries.
- d) Charge the product indoors only.
- e) Protect the charger against moisture and wet conditions. There is a danger of electric shock.
- f) Do not cover the battery charger. Otherwise, the battery charger can overheat and no longer operate properly.
- g) Always charge the battery at a temperature of 0°C–40°C. A temperature of less than 0°C will result in over charging which is dangerous. The battery cannot be charged at a temperature higher than 40°C. The most suitable temperature for charging is that of 20°C–25°C.

## RESIDUAL RISKS

- a) Familiarise yourself with the use of this product by means of this instruction manual. Memorise

the safety directions and follow them to the letter. This will help to prevent risks and hazards. Always be alert when using this product, so that you can recognise and handle risks early. Fast intervention can prevent serious injury and damage to property. Switch off and disconnect from the battery if there are malfunctions.

- b) Even if all instructions are strictly followed, there are still some factors that could lead to hazards, such as :
- Thrown out pieces of the work piece.
  - Vibration injuries : use designated handles and try to reduce working time and exposure.
  - Injuries caused by noise : wear ear protection and reduce working time and exposure.
  - Inhalation of dust and particles.
  - Wear eye protection at all times.

If you experience any of these factors while using the machine, stop the machine consult your doctor immediately

- c) Injuries may be caused or aggravated by prolonged use of a tool. When using any tool for prolonged periods, ensure you take regular breaks.

- d) Prolonged use of the product exposes the user to vibrations that can cause a range of conditions collectively known as hand-arm vibration syndrome (HAVS) e.g. fingers going white; as well as specific diseases such as carpal tunnel syndrome.
- e) To reduce this risk when using the product, always wear protective gloves and keep your hands warm.

### **INTENDED USE**

This chain saw is only intended to be used for basic limbing, felling, woodcutting, and remove buttress roots. All of the wooden objects intended to be cut with this chain saw should be no thicker than the guide bar's maximum cutting capabilities. Do not use it for others purposes.

# KNOW YOUR UNIT

## APPLICATIONS

Model: CSX2-M1

As a chainsaw:

Limbing, felling, woodcutting, and remove buttress roots.

1	Battery Pack
2	Unlock Button of Battery Pack
3	Rear Handle
4	Trigger Lock-out
5	Guard with Chain Brake
6	Guide Bar
7	Saw Chain
8	Guide Bar Cover
9	Oil Tank Cap
10	Auxiliary Handle
11	Switch Trigger
12	Side Cover
13	Side Cover Nut
14	Tensioning Gear

# SPECIFICATIONS\*





## NOTE:

CSX2-M1-0 does not include the charger and the battery pack.

Model	CSX2-M1
Rated voltage	18V d.c.
No-load speed	6000/min
Specified chain pitch	3/8
Specified gauge	0.043mm

Type of chain	104MLEA041, AP10-40-437P
Type of guide bar	90PX040X,3/80.43-40S
Drive sprocket: Number of teeth and pitch	6
Length of the guide bar	254mm
Cutting capacity	11m/s
Oil capacity	60ml
Weight (without battery, saw chain and guide bar )	4.19lbs
Sound pressure level	81.2dB(A), K=3dB(A)
Measured sound power level	92.2dB(A), K=3dB(A)
Guarantee sound power level	97dB(A)
Vibration level(K=1m/s <sup>2</sup> )	1.7m/s <sup>2</sup>

<b>Battery pack model for option</b>	B20X2
Rated voltage	18V  , 20V Max.
Rated capacity	2.0Ah
Weight	Approx. 0.335kg
<b>Battery pack model for option</b>	B40X2
Rated voltage	18V  , 20V Max.
Rated capacity	4.0Ah
Weight	Approx. 0.65kg

<b>Charger model for option</b>	CHX2
Rated input	100-240V ~ 50/60Hz
Rated output	21V, 2A
Charging time (with 2.0 Ah battery)	75mins
Charging time (with 4.0 Ah battery)	140mins
Protection class	 / II
Weight	Approx. 0.34kg
<b>Charger model for option</b>	CHQX2
Rated input	100-240V ~ 50/60Hz
Rated output	21V, 4A



Charging time (with 2.0 Ah battery)	35mins
Charging time (with 4.0 Ah battery)	70mins
Protection class	□ / II
Weight	Approx. 0.482kg

## NOISE/VIBRATION INFORMATION

The declared vibration total value(s) and the declared noise emission value(s) have been measured in accordance with a standard test method and may be used for comparing one tool with another. They may also be used in a preliminary assessment of exposure.



### WARNING:



The vibration and noise emissions during actual use of the power tool can differ from the declared values depending on the ways in which the tool is used especially what kind of workpiece is processed.



It is necessary to identify safety measures to protect the operator that are based on an estimation of exposure in the actual conditions of use (taking account of all parts of the operating cycle such as the times when the tool is switched off and when it is running idle in addition to the trigger time).

Please try to minimize the exposure of vibration and noise. Typical measure for reducing exposure will be wearing of hand gloves and hearing protection during operation, limiting working time and applying accessories in good condition.

## ASSEMBLY

1. Unpack all parts and lay them on a flat, stable surface.
2. Remove all packing materials and shipping devices, if applicable.
3. The scope of delivery varies depending on the country and purchased variant:  
Model of CSX2-M1
  - Chainsaw x1
  - Instruction manual x1
  - Guide bar x1
  - Guide bar cover x1
  - Saw chain x1
  - Wrench x1
  - Battery pack x1
  - Charger x1

4. If you find that parts are missing or show damage do not use the product but contact your dealer. Using an incomplete or damaged product represents a hazard to people and property.
5. Ensure that you have all the accessories and tools needed for assembly and operation. This also includes suitable personal protective equipment.



### NOTE:

CSX2-M1-0 does not include the charger and the battery pack.



### WARNING:



Wear protective gloves for this assembly work and always lay the product on a flat and stable surface while assembling.



Follow the assembly instructions step-by-step and use the pictures provided as a visual guide to easily assemble the product!

Do not insert the battery pack before the power tool is completely assembled or adjusted!

## INSTALLING THE SAW CHAIN AND THE GUIDE BAR



### WARNING:

Ensure the battery pack is removed from the chainsaw before attaching the bar and chain.

1. Totally loosen the side cover nut counterclockwise with the assistance of wrench. Then remove the side cover (Fig.2).
2. Loop the new saw chain into the slot of the guide bar according to the provided figure (Fig.3).
3. Install the guide bar and the saw chain on the drive sprocket (Fig.4). Adjust the tensioning gear when the guide bar and saw chain can not be mount over the drive sprocket (Fig.5).
4. Pull the chain around the guide bar with your gloved hand or using auxiliary tools to make sure it can run smoothly.



### NOTE:

It is still recommended to check for smoothness of the saw chain before operation even after using it for a period of time.

5. Replace the side cover and slightly tighten the side cover nut (Fig.2). Do not tighten too much. Meanwhile, protect the saw chain from sliding out.
6. Twist the tensioning gear till the saw chain can be lifted

- by 2-3 mm from the center of the guide bar.  
7. Fully tighten the side cover nut clockwise (Fig.2).



## NOTE:

After a short period of use, allow the chain to cool, remove the battery and check the tension again.

## BAR AND CHAIN OIL FILLING



## WARNING:

Bar and chain oil prevents premature wear. Never operate the chainsaw if oil is not visible. Check oil level frequently and fill as needed.



## NOTE:

Bar and chain oil is required to properly lubricate the guide bar and saw chain. The chainsaw is equipped with an automatic oiler that deposits oil on the bar and chain when running, keeping them properly lubricated.

1. Place the chainsaw on its side on a firm, flat surface, so that the oil tank cap is on top.
2. Clean any debris from the cap area.
3. Remove the oil tank cap (Fig.6).
4. Carefully pour the bar and chain oil into the tank.
5. Replace the cap and make sure oil is visible in the tank.

## INSTALLING/REMOVING THE BATTERY PACK

To install:

Slide the battery pack to the battery docking port on the product until it clicks (Fig.7).

To remove:

Press the unlock button on the battery pack and slide the battery pack out.

## OPERATION



## WARNING:

Never operate a chain saw that is damaged or improperly adjusted or that is not completely and securely assembled. Be sure that the saw chain stops moving when the power control system trigger is released. Never adjust the guide bar or saw chain when the engine is operating.

## TESTING THE CHAIN BRAKE

This chainsaw is designed with a function of chain brake on the guard, which stops both the motor and the motion of the chain when kickback occurs. The chain brake can be activated by pushing the guard forward as the saw rotates backward during kickback. Make sure the chain brake is working before using the chainsaw.

To check brake operation (Fig.8):

- Place the saw on a firm, flat surface.
- Start the saw briefly.
- Push the guard forward to activate the function of chain brake. A properly functioning chain brake stops the motor and saw chain immediately. If the motor and saw chain do not stop immediately, have the chain brake checked at an approved service location.
- Release the switch trigger.
- Return to operating position.

## PRIMING THE OILER



## WARNING:

Keep hands, clothing, and hair away from the drive sprocket when priming the oiler.



## NOTE:

Prime the oiler before the first use or after being stored for a long time.

It is essential to fill with oil before use. Operating the chainsaw without bar and chain oil will result in damage to the chain saw. The chain is automatically lubricated with oil during operation via the oil outlet (Fig.9).

1. Insert the battery.
2. Run the chainsaw for about two minutes.
3. Remove the battery.
4. Remove the side cover.
5. Check for oil on the bar.

## TENSIONING THE SAW CHAIN



## NOTE:

Check the tension between the saw chain and the guide bar before every starts of the chainsaw.



## WARNING:

Only tension the saw chain when the chain is cool. A hot chain may contract and damage the guide bar or chain as it cools.

1. It is no need to remove the side cover for adjusting the chain tensioning gear (Fig.5). Just loosen the side cover nut slightly by a wrench to unlock the guide bar and saw chain which completely locked during operation.
2. Twist the tensioning gear till the chain come to a suitable tension status. The correct chain tension is reached when the saw chain can be lifted by 2-3 mm from the center of the chain bar.
3. Tighten the side cover nut after adjustment.



## NOTE:

If the chain is still loose when the saw is at maximum tension, replace the chain.

## SWITCHING ON/OFF



## WARNING:

Follow the instructions in your operator's manual for starting the chain saw and control the chain saw with a firm grip on both handles when it is in operation. Always hold the chain saw with your right hand on the rear handle and your left hand on the front handle. Keep handles dry, clean, and free of oil.

Ensure the guard is at operation position. If not, turn it back to the operation position.

Keep the trigger lock-out being pressed at first, then squeeze the switch trigger to start the product. Just release the trigger lock-out once the chainsaw starts. To turn off the chainsaw, release the switch trigger (Fig.10).

## OVERHEAT PROTECTION OF CHAINSAW

When the temperature of PCB is above 248°F(120°C) during operation, The chainsaw will be shut down automatically. Wait it to cool down for about five minutes then restart the product.

## GENERAL SAWING TECHNIQUES



## NOTE:

It is recommended that first-time user should, as a minimum practice, cutting logs on a saw-horse or cradle.

- Saw off the lower branches on the tree first. By doing so, it is easier for the cut branches to fall to the ground.

- At the end of the cut, the weight of the saw suddenly increases for the user since it is no longer being supported by a branch. There is a risk of losing control of the saw, so make sure to stay alert during the entire sawing operation.
- Only pull the saw out of a cut while the saw is running. By doing so, you prevent the chain from jamming in the wood.
- DO NOT saw with the tip of the chain bar. DO NOT saw into the branch formations (where the tree branches outwards). This will impede the tree's ability to heal.
- For sawing off smaller branches, place the stop face of the saw on the branch. This prevents unwanted movements of the saw at the beginning of the cut. While applying light pressure, guide the saw through the branch from top to bottom.
- For sawing off larger branches, first make a relief cut. Saw through 1/3 of the branch diameter from the bottom to top using the top side of the chain bar. Then saw from top to bottom for the other 2/3 using the bottom side of the chain bar. Saw off longer branches in sections in order to maintain control over the location of impact.

## FELLING A TREE

When cross-cutting/bucking and felling operations are being performed by two or more persons at the same time, the felling operations should be separated from the crosscutting/bucking operation by a distance of at least twice the height of the tree being felled.

Trees should not be felled in a manner that would endanger any person, strike any utility line or cause any property damage. If the tree does make contact with any utility line, the company should be notified immediately.

The chain saw operator should keep on the uphill side of the terrain as the tree is likely to roll or slide downhill after it is felled.

An escape path should be planned and cleared as necessary before cuts are started. The escape path should extend back and diagonally to the rear of the expected line of fall (Fig.11).

Before felling is started, consider the natural lean of the tree, the location of larger branches and the wind direction to judge which way the tree will fall.

Remove dirt, stones, loose bark, nails, staples and wire from the tree.

## NOTCHING UNDERCUT

Make the notch 1/3 the diameter of the tree, perpendicular to the direction of falls (Fig.12). Make the lower horizontal notching cut first. This will help to avoid pinching either the saw chain or the guide bar when the second notch is being made.

## FELLING BACK CUT

Make the felling back cut at least 2inch(50 mm) higher than the horizontal notching cut (Fig. 12). Keep the felling back cut parallel to the horizontal notching cut. Make the felling back cut so enough wood is left to act as a hinge. The hinge wood keeps the tree from twisting and falling in the wrong direction. Do not cut through the hinge.

As the felling gets close to the hinge, the tree should begin to fall. If there is any chance that the tree may not fall in desired direction or it may rock back and bind the saw chain, stop cutting before the felling back cut is complete and use wedges of wood, plastic or aluminium to open the cut and drop the tree along the desired line of fall. When the tree begins to fall, remove the chain saw from the cut, stop the motor, put the chain saw down, then use the retreat path planned. Be alert for overhead limbs falling and watch your footing.

## LIMBING A TREE

Limbing is removing the branches from a fallen tree. When limbing leave larger lower limbs to support the log off the ground. Remove the small limbs in one cut (Fig.13). Branches under tension should be cut from the bottom up to avoid binding the chain saw.

## CROSS-CUTTING/BUCKING A LOG

Cross-cutting/bucking is cutting a log into lengths. It is important to make sure your footing is firm and your weight is evenly distributed on both feet. When possible, the log should be raised and supported by the use of limbs, logs or chocks. Follow the simple directions for easy cutting.

When the log is supported along its entire length (Fig. 14), it is cut from the top (overbuck).

When the log is supported on one end (Fig.15), cut 1/3 the diameter from the underside (underbuck). Then make the finished cut by overbucking to meet the first cut.

When the log is supported on both ends (Fig.16), cut 1/3 the diameter from the top (overbuck). Then make the finished cut by underbucking the lower 2/3 to meet the first cut.

When cross-cutting/bucking on a slope always stand on the uphill side of the log (Fig. 17).

When "cutting through", to maintain complete control, release the cutting pressure near the end of the cut without relaxing your grip on the chain saw handles.

Don't let the chain contact the ground. After completing the cut, wait for the saw chain to stop before you move the chain saw. Always stop the motor before moving from tree to tree.

## CHARGING THE BATTERY PACK



### WARNING:

This Lithium-Ion battery pack is shipped partially charged. Fully charge the battery pack before using it for the first time.

1. Charge the Lithium-Ion battery pack only with the correct charger.
2. Connect the charger to a power supply, the light indicator of the charger turns red.
3. Align the raised ribs of the battery pack with the slot in the charger.
4. Insert the battery pack into the charger, the light indicator of the charger turns green and it flashes (Fig.18).
5. The charger will communicate with the battery pack to evaluate the condition of the battery pack.
6. It is fully charged that the four lights of the battery turn on. Disconnect the power supply from the charger. Remove battery pack from the charger.

## CHARGING INDICATOR

Press the light button on the battery pack to check whether it needs to charge (Fig.19) .

Lights			Status
Lighted	Off	Blinking	
			The battery is at full capacity.
			The battery is at 75% capacity.
			The battery is at 50% capacity and requires charging.
			The battery is at 25% capacity and requires charging soon.
			The battery is less than 5% capacity and requires charging immediately.



### WARNING:

Malfunctions may occur when the four lights blinking in turns.

## OVERHEAT PROTECTION

When the tool/battery is overheated, the tool stops automatically. In this situation, let the power tool/battery cool before turning the tool on again.

## OVERDISCHARGE PROTECTION

When the battery capacity is not enough, the tool stops automatically. In this case, remove the battery from the tool and charge the battery.

## MAINTENANCE



### WARNING:

Failure to identify and replace damaged or worn parts can cause serious personal injury. Inspect the chainsaw regularly. Regular inspection is the first step to proper maintenance. Follow the guidelines below to maximize safety and satisfaction. Have any damaged or excessively worn parts replaced immediately.



### WARNING:

Always remove the battery pack and let the product completely cool down before performing cleaning and maintenance work!  
Always wear gloves to reduce the risk of injury when operating this unit.  
Only perform cleaning and maintenance work according to these instructions! All further works must be performed by a qualified specialist!

## REPLACING/CHANGING THE SAW CHAIN AND GUIDE BAR

Exchange a worn guide bar/chain saw refers to "INSTALLING THE SAW CHAIN AND THE GUIDE BAR". Only use the specified parts for replacements.

## SHARPENING THE SAW CHAIN

Do not sharpen the saw chain by yourself, unless you are experienced in doing so. It is recommended to have the chain saw sharpened by an authorized service.

## CLEANING

- Remove the battery.
- Remove wood chips and other debris from the battery port. Clean dirty contacts with a soft, dry cloth. Dirt or oil can cause a poor electrical connection, resulting in loss of power.



### WARNING:

There are no user serviceable parts inside the battery pack. Do not disassemble.

- After use, clean debris from the saw chain and guide bar. Wipe power head with a clean cloth moistened with a mild soap solution. Never use harsh cleaners or solvents.
- Always clean out wood chips, saw dust and dirt from the bar groove when replacing saw chain.
- Ensure that the chain tensioning gear is free of wood chips and other debris.



### NOTE:

When cleaning the chainsaw powerhead, do not immerse in water or other liquids.

## TRANSPORT

- Remove battery pack from the chainsaw.
- Install the guide bar cover.
- If desired, drain the bar and chain oil to reduce seepage.
- Carry saw with bar and chain facing behind the operator.
- Tools can shift during transport. Ensure the tool is secure and cannot fall or move into contact with people or property.

## STORAGE

- Remove the battery pack from the chainsaw.
- Clean chainsaw thoroughly as described above.
- Install the guide cover and place an absorbent pad under the bar.
- Store in a dry place.
- Keep out of reach of children or pets.
- We recommend using the original package for storage or covering the product with a suitable cloth or enclosure to protect it against dust.



### NOTE:

To prolong battery life, never store battery pack in a completely discharged condition. Make sure the battery pack is charged once per year or when the LED indicator shows only one light.

# TROUBLESHOOTING

Suspected malfunctions are often due to causes that the users can fix themselves. Therefore, check the product using this section. In most cases the problem can be solved quickly.

PROBLEM	POSSIBLE CAUSE	SOLUTION
Motor does not run or runs intermittently	Chain brake engaged	Before starting, make sure the hand guard is in its most rearward position (chain brake disengaged). For correct hand guard position, see "SWITCHING ON/OFF" in this manual.
	Battery discharged	Recharge. See "CHARGING THE BATTERY PACK" in this manual.
	Trigger lock-out not opened	See "SWITCHING ON/OFF" in this manual.
	Battery pack not fully inserted	Clean debris from the battery port and terminals with a clean dry cloth or non-conductive brush.
	Debris in side cover	Remove battery pack, then remove side cover and clean out debris.
	Battery pack cold	Allow battery to warm above the minimum operating temperature of 32°F (0°C).

Low cutting efficiency	Dull / worn chain	Sharpen or replace the chain.
	Dry chain	Check the oil level. Refer to "OIL FILLING".
	Over tensioned chain	Adjust the chain tensioning gear to the appropriate tension.
	Improper cutting technique	Follow guidelines in "CUTTING" in this manual.
Chain brake does not engage	Debris in side cover	Remove battery pack, then remove side cover and clean out debris.
	Battery pack not fully charged	Recharge. Refer to "CHARGING THE BATTERY PACK".
	Debris preventing full movement of hand guard	Clean debris from external chain brake mechanism.
	Possible chain brake malfunction	Contact an approved service location immediately.
Chainsaw does not cut properly	Insufficient chain tension	Adjust the tensioning gear again.
	Dull / worn chain	Sharpen or replace the chain.
	Chain installed backwards	Assemble the chain again as the figure on the cover side.
	Dry or excessively stretched chain	Check the oil level. Refer to "OIL FILLING".

Battery pack does not charge	Battery pack over/under temperature protection is activated	This may occur when the saw is run continuously or exposed to high ambient temperatures. Allow the battery pack to reach the acceptable temperature before charging.
	Dirty or damaged contacts on battery pack or charger	Inspect the contacts on the both the battery pack and charger. If necessary, clean according to the instructions in this manual. Reinsert battery pack into the charger, making sure it is fully seated.
	Battery pack is at the end of its life	All batteries have a limited life. If the battery pack is more than two years old or has been recharged frequently, it may be time to replace it. Replace only with the battery pack specified for this chainsaw.
	Charger faulty	Have the function checked at an approved service location.

## RECYCLING AND DISPOSAL



Disposal of waste electric and electronic equipment (WEEE)

Waste electric and electronic equipment shall not be disposed of with household waste. Please recycle where facilities exist. Check with your local authority for recycling advice.



Disposal of defective or used battery pack

Discharge your battery pack by operating your tool, then remove the battery pack from the tool. Cover the battery pack connections with heavy duty adhesive tape to prevent short circuit and energy discharge.

Do not attempt to open or remove any of the components.

Batteries and battery packs shall not be disposed of with household waste. Consult your local waste authority for information regarding available recycling and/or disposal options.

# PARTS

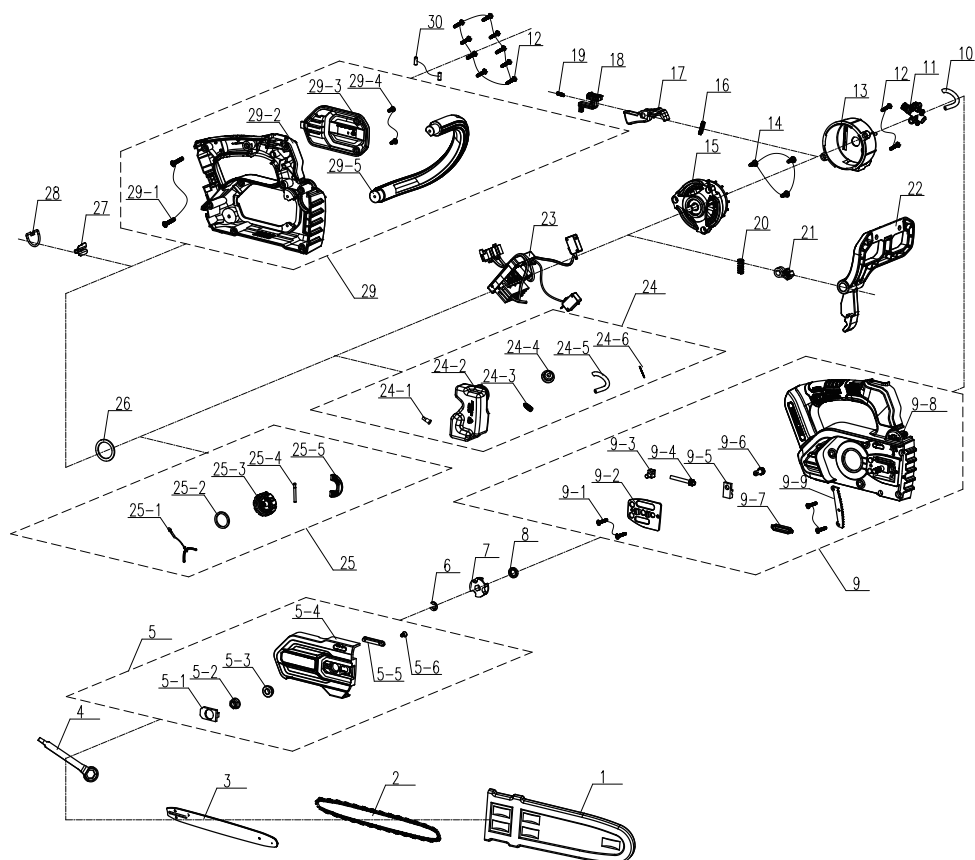

No.	Part #	Description	Qty.
1	8331-431201-00	Guide bar cover	1
2	8344-433201-00	Saw chain	1
3	A013029-014-00	Guide bar	1
4	8261-463101-00	Wrench	1
5	A013029-004-00	Side cover assembly	1
5-1	A013021-023-00	Fixing plate	1
5-2	8NG-08	Hexagon flange nuts	1
5-3	8334-463101-00	Axle sleeve	1



5-4	A013021-040-00	Side cover	1
5-5	8208-438801-00	Side cover seal ring	1
5-6	8SEAB40-08	Cross recessed countersunk head tapping screws	1
6	8CE-07	E-type retaining ring	1
7	8128-462202-00	Sprocket	1
8	F022009-019-00	Output shaft sleeve	1
9	A013029-005-00	Housing assembly	1
9-1	8SJAB40-16	Self tapping screw	4
9-2	A013021-026-00	Insulation gasket	1
9-3	A013021-029-00	Tightening nut	1
9-4	A013021-028-00	Tightening screw	1
9-5	A013021-027-00	Fixing plate	1
9-6	8123-965602-01	Tensioning gear	1
9-7	A013004-013-00	Seal ring	1
9-8	A013021-012-00	Housing	1
9-9	A013035-015-00	Woodcutters	1
10	234-1003	Transparent tubing	0.065m
11	A013003-022-00	Oil pump assembly	1
12	8SJAB40-16	Self tapping screw	11
13	A013021-014-00	Cover	1
14	8SJAB50-14	Self tapping screw	3
15	A013029-002-00	Motor assembly	1
16	8342-463002-00	Push button spring	1
17	A013021-013-00	Trigger	1
18	A013021-022-00	Trigger lock-out	1
19	8342-691302-00	Compression spring	1
20	A013003-031-00	Compression spring	1
21	8304-438401-00	Guard plate positioning block	1
22	A013021-015-00	Guard	1
23	A013029-003-00	Electronic components	1
24	A013021-033-00	Oil tank assembly	1
24-1	8335-481201-00	Valve	1
24-2	A013021-018-00	Oil tank	1
24-3	8342-437501-02	Conical compression spring	1
24-4	8208-462503-00	Oil tank outlet sealing ring	1
24-5	234-1003	Transparent tubing	0.075m
24-6	8342-000002-00	Oil tube setting spring	0.04m

25	A014005-007-00	Oil tank cover assembly	1
25-1	8088-481501-01	Anti loss hook of oil tank cap	1
25-2	8208-431901-01	Seal ring	1
25-3	A014005-008-00	Oil tank cap	1
25-4	A013010-017-00	Cylindrical pin	1
25-5	A014005-010-00	Bracket	1
26	8341-491801-00	Rubber pad	1
27	A013021-025-00	Fixing plate	1
28	A013021-020-00	Hook	1
29	A013029-006-00	Housing assembly	1
29-1	8SJAB40-25	Cross grooved pan head tapping screw	2
29-2	A013021-011-00	Housing	1
29-3	A013021-042-00	Cover	1
29-4	8SJGB40-12	Screw	2
29-5	A013021-019-00	Auxiliary Handle	1
30	B048019-034-00	Rubber column	2







